

# Outdoor Heritage Fund Grant Application



## Instructions

After completing the form, applications and supporting documentation may be submitted by e-mail to [ndicgrants@nd.gov](mailto:ndicgrants@nd.gov). It is preferred that only electronic copies are submitted.

You are not limited to the spacing provided, except in those instances where there is a limit on the number of words. If you need additional space, please indicate that on the application form, answer the question on a separate page, and include with your submission.

The application and all attachments must be received by the application deadline. You may submit your application at any time prior to the application deadline. **Applicants are strongly encouraged to submit applications prior to the deadline for staff review in order ensure that proposals will be complete when submitted on deadline date.** Incomplete applications may not be considered for funding.

**Please review the back of this form to determine project eligibility, definitions, budget criteria, and statutory requirements.**

Project Name: TMBCI Fishing/Boat Access Project

Name of Organization: Turtle Mountain Band of Chippewa

Federal Tax ID# : #450223071

Contact Person/Title: Jeff Desjarlais, Jr., TMBCI Natural Resources Director

Address: Box 900, Highway 281 W

City: Belcourt

State: North Dakota

Zip Code: 58316

E-mail Address: [desjarlais.jeffrey@yahoo.com](mailto:desjarlais.jeffrey@yahoo.com)

Web Site Address (If applicable): [www.tmchippewa.com](http://www.tmchippewa.com)

Phone: 701-477-2640

List names of co-applicants if this is a joint proposal

**MAJOR Directive:**

Choose only one response

**Directive A.** Providing access to private and public lands for sportsmen, including projects that create fish and wildlife habitat and provide access for sportsmen;

**Directive B.** Improving, maintaining and restoring water quality, soil conditions, plant diversity, animal systems and by supporting other practices of stewardship to enhance farming and ranching;

**Directive C.** Developing, enhancing, conserving and restoring wildlife and fish habitat on private and public lands; and

**Directive D.** Conserving natural areas and creating other areas for recreation through the establishment and development of parks and other recreation areas.

**Additional Directive:**

Choose all that apply

**Directive A.**

**Directive B.**

**Directive C.**

**Directive D.**

**Type of organization:**

State Agency

Political Subdivision

Tribal Entity

Tax-exempt, nonprofit corporation.

**Abstract/Executive Summary.**

Summarize the project, including its objectives, expected results, duration, total project costs and participants. (no more than 500 words)

The Turtle Mountain Band of Chippewa proposes to purchase seven (7) handicapped accessible Fishing/Boat Access Docks to be installed at five tribal lakes for the purpose of expanding recreational opportunities as well as providing lake access for water quality testing. This is critical to improving tribal fish & wildlife habitats so that current and future generations of tribal members and our visitors to the reservation can continue to enjoy the abundance of natural resources on the reservation.

The total amount requested from the ND Outdoor Heritage Fund is \$117,000 and the tribe will contribute \$29,400 in cash and in-kind tribal resources for a total project budget of \$146,400. The Fishing/Boat Access Docks will be purchased from the local tribal manufacturing company – Metalworks. The TMBCI Natural Resources Department will provide equipment and manpower to:

conduct preparatory site work; develop a handicapped-only parking area; construct cement walkways; purchase signage & parking posts/chains, and; landscape around the lakefront perimeters.

The tribal Natural Resources Department will be responsible for maintaining and grooming the lakefront beach areas, the handicapped parking lot area, the cement walkways, and the Fishing/Boat Access Docks.

Goal: To purchase and install seven (7) Fishing/Boat Access Docks for the purpose of expanding recreational opportunities and to conduct water quality assessment activities for the benefit of fish & wildlife on the Turtle Mountain Chippewa Reservation.

Objectives:

1. Conduct site work in preparation of handicapped park area and cement walkways.
2. Purchase and install seven (7) handicapped accessible Fishing/Boat Access Docks from local tribal manufacturing firm – Metalworks.
3. Install seven Docks at seven tribal lakes.
4. Landscape the landscape area and plant new native trees and shrubs.
5. Promote Fishing/Boat Project in media publications (TM Times, TM Star, TMBCI Web).
6. Properly maintain the lakefront areas for seasonal usage (fall, winter, spring, summer).

**Project Duration:** One year from start to completion of project activities.

**Indicate the intended schedule for drawing down OHF funds.**

Turtle Mountain Band of Chippewa intends to draw down funds upon completion of project activities.

**Amount of Grant request: \$117,000**

**Total Project Costs: \$146,400**

Note: in-kind and indirect costs can be used for matching funds.

**Amount of Matching Funds: \$29,400**

**A minimum of 25% Match Funding is required.** Indicate if the matching funds will be in-kind, indirect or cash. Please provide verification that these matching funds are available for your project. Note that effective as of July 1, 2015 no State General Fund dollars can be used for a match unless funding was legislatively appropriated for that purpose.

Amount of Match	Funding Source	Type of Match (Cash, In-kind or Indirect)
\$ 20,000	Turtle Mountain Band of Chippewa	In-Kind
\$ 9,400	Turtle Mountain Band of Chippewa	Cash

\$		
\$		
\$		
\$		

**Certifications**

x I certify that this application has been made with the support of the governing body and chief executive of my organization.

x I certify that if awarded grant funding none of the funding will be used for any of the exemptions noted in the back of this application.

**Narrative**

**Organization Information – Briefly summarize your organization’s history, mission, current programs and activities.**

Include an overview of your organizational structure, including board, staff and volunteer involvement. (no more than 300 words)

The TMBCI Tribal Government oversees the Department of Natural Resources (NR) who manages the wildlife and fish, bison, parks and recreation, agricultural, and other natural and cultural resources on Turtle Mountain Tribal lands. The NR Department maintains a full-time staff and partners with local training programs such as Summer Youth, Adult Workforce Training, and Experience Works (tribal elders age 55 and over) to assist the NR throughout the year.

*Mission Statement: The Turtle Mountain Band of Chippewa is committed to preserving and protecting the natural and cultural resources of the Turtle Mountain Indian Reservation for the benefit of present and future generations of tribal members and for those who visit our Reservation. As a tribal nation, it is an obligation and duty to protect our natural resources. It is inherited within our traditional beliefs that have been passed down for generations. It is also critical that we pass down to our youth the importance of preserving our natural resources. This is best practiced through “holistic teachings” and the integration of educational and cultural programming, recreational and wellness activities, and outdoor experiential learning.*

**Purpose of Grant – Describe the proposed project identifying how the project will meet the specific directive(s) of the Outdoor Heritage Fund Program**

Identify project goals, strategies and benefits and your timetable for implementation. Include information about the need for the project and whether there is urgency for funding. Indicate if this is a new project or if it is replacing funding that is no longer available to your organization. Identify any innovative features or processes of your project. Note: if your proposal provides funding to an individual, the names of the recipients must be reported to the Industrial Commission/Outdoor Heritage Fund. These names will be disclosed upon request.

For tree/shrub/grass plantings: provide a planting plan describing the site design, planting methods, number of trees/shrubs by species and stock size, grass species and future maintenance. A statement certifying that the applicant will adhere to USDA-NRCS tree/shrub/grass planting specifications along with the name of the governmental entity designing the planting may be substituted for a planting plan.

For projects including Section 319 funding: provide in detail the specific best management practices that will be implemented and the specific projects for which you are seeking funding.

For projects including fencing: A minimum cost share of 40% by the recipient is preferred. Include detailed information on the type of fencing to be installed, whether funding is requested for boundary fencing, new or replacement of existing fencing, and/or cross fencing.

The Turtle Mountain Band of Chippewa proposes to purchase seven (7) handicapped accessible Fishing/Boat Access Docks to be installed at seven tribal lakes for the purpose of expanding recreational opportunities as well as providing lake access for water quality testing. This is critical to improving tribal fish & wildlife habitats so that current and future generations of tribal members and our visitors to the reservation can continue to enjoy the abundance of natural resources on the reservation.

Goal: To purchase and install seven (7) Fishing/Boat Access Docks for the purpose of expanding recreational opportunities and to conduct water quality assessment activities for the benefit of fish & wildlife on the Turtle Mountain Chippewa Reservation.

Objectives:

- 1) Conduct site work in preparation of handicapped park area and cement walkways.
- 2) Purchase and install seven (7) handicapped accessible Fishing/Boat Access Docks from local tribal manufacturing firm – Metalworks.
- 3) Install seven Docks at seven tribal lakes.
- 4) Landscape the landscape area and plant new native trees and shrubs.
- 5) Promote Fishing/Boat Project in media publications (TM Times, TM Star, TMBCI Web)
- 6) Properly maintain the lakefront areas for seasonal usage (fall, winter, spring, summer).

Each of the tribal host opportunities for fishing, walking and nature trails, swimming and water sports, individual and group picnic facilities, and wildlife viewing opportunities -- as these may be developed carefully within the context of an integrated stewardship and management plan.

The TMBCI Natural Resources in the midst of updating its Park Management Plan and have identified the need to conduct thorough water quality analysis and studies in each of our tribal lakes. This will also help determine which lakes would be suitable for a sustainable fish habitat. Along with the studies will be implementation plan strategies that will include timelines, budgets, and infrastructure needs. The need for water studies was reiterated in the tribe's recently adopted tribal Fish Management Plan for 2018-2028.

In the forthcoming months, the tribe will be hiring a full-time.....to assist the Natural Resources Department in developing the tribal fishery management project. Following is the tentative job duties.

Fish & Wildlife Biologist/Project Coordinator - GS 12 Permanent Full-time

Serve as a Fish & Wildlife Biologist responsible for technical assistance and monitoring plans and programs related to Turtle Mountain Band of Chippewa Indians (TMBCI) fish & wildlife program. Prepare and submit program budgets, goals and objectives to conform available funds to comply with policies, standards and procedures. Recommend actions relating to litigation and negotiation support concerning fisheries program activities. Monitor anadromous fish & wildlife regulatory actions of the area to ensure regulations do not deprive members of the band the opportunity to harvest their share of the fish and wildlife resources. Responsible for managing budgets and prepare annual budget estimates and distributions based on allotted funds. Prepares, conducts or coordinates consultation required by Section (7) of the Endangered Species Act for actions taken by or on behalf of the TMBCI effecting listed marine and freshwater aquatic species.

The handicapped fishing piers will be constructed by the local tribal manufacturing firm – Metalworks Industries. The firm has built fishing piers for the Natural Resources Department in the past and they have been a popular addition to our lakes. Metalworks has also fabricated metal bench braces, garbage bins, and other necessary amenities for the Natural Resources Department. The docks will be constructed using USA made materials as that is policy of the tribe and a directive given to tribal enterprises.

The Turtle Mountain Community College, has agreed to assist the tribe by instructional support and training for future natural resource specialist. They have also offered to provide internship to students interested in participating in water studies and other research.

Each fishing/boat dock site is in need of leveling and tree and shrub removal as well as watershed embankment work. The tribe has heavy equipment available such as large bulldozers, scrapers, and hauling trucks that will be used for clearing and landscaping. One dock will be situated at each of the following lakes – Martin, Crow, Wheaton, Schute, Crow, Jarvis, & Black Duck.

The Natural Resources Department will construct a handicapped parking only area at Lake Schute and Black Duck Lake. These lakes are the most accessible and will be adequately suitable for cement walkway to the water shorelines. These sites will have signage posted to assure they will be handicapped-only parking.

Although the fishing/boat docks will have multi-functional usage (expanded fishing opportunities, handicapped accessibility), it ultimately will provide our tribal Natural Resources department access to waterways for water quality studies and related research. The health of our lakes supersedes the tribe's ability to capitalize on fish & wildlife resources, tourism, a sustainable water Marina, etc.

The NR Director, working collaboratively with the tribal Promotion/Media Specialist, will promote the new Fishing/Boat Access Project in all available media campaigns and outlets. The tribal Tourism Department is an active member with several state and national Tourism organizations that promote

tourism activities in Indian Country. The Turtle Mountain Band of Chippewa is a big draw due to its cultural significance and natural landscape and bountiful waterways.

Timeline:	Month 1-3	Survey and stake out dock/parking sites Pre-order docks from Metalworks Pre-order signage from tribal Print Shop Purchase sign poles & hardware Prepare quarterly progress report
	Months 4-6	Construction of docks. Heavy machinery site work Prepare quarterly progress report
	Months 7-9	Continued construction of docks Heavy machinery site work Prepare quarterly progress report
	Months 10-12	Installation of docks Installation of signage Landscaping and tree planting Initiate media campaign Prepare final summation progress report

Major benefits of the proposed Fishing/Boat Access Dock Project include:

1. Provide additional fishing and recreational opportunities for tribal members.
2. The docks will be handicapped accessible
3. Allow access to smaller lakes for water quality studies and research.
4. Railing will provide additional safety to fishing patrons.
5. Will enhance the local tribal tourism industry.
6. Provide healthy environment that promotes social, mental and physical well-being

is project part of a Comprehensive Conservation Plan    Yes    No

If yes, provide a copy with the application. A copy of TMBCI Fishery Plan is included w/application

*Note: Projects involving buildings and infrastructure will only be considered if part of a Comprehensive Conservation Plan. Please refer to the "Definitions" section at the back of the form for more details.*

**Management of Project – Provide a description of how you will manage and oversee the project to ensure it is carried out on schedule and in a manner that best ensures its objectives will be met.**

Include a brief background and work experience for those managing the project.

The Sky Chief Park complex is managed by the tribal Natural Resources Department and is headed by Mr. Jeff Desjarlais, Jr (JJ). Mr. Desjarlais is spearheading the Fishing/Boat Access Dock project in collaboration with several key partners/stakeholders who have been involved since the development phase of the project including the TMBCI Tribal Government and the TM BIA Agency.

The TMBCI Tribal Government ([www.tmchippewa.com](http://www.tmchippewa.com)) provides a steady source of funding toward the tribal Natural Resources Department and oversees a diverse array of federal, state, and tribal programs on behalf of the tribe. A professional Financial Audit is conducted yearly. The Bureau of Indian Affairs (BIA) has trust responsibilities and provides funding for our Natural Resources including a Youth/Elder mentoring employment program.

The NR Department meet bi-weekly to discuss developmental efforts & implementation strategies in regard to the Sky Chief Park complex. During the meetings, conference calls and video chats are set up with a host of agencies that have contributed to the needs of the tribe's natural resources. To assure progress success, the NR Department is guided by several plans in relation to stewarding the tribe' natural resources including:

- TMBCI Sky Chief Park Management Plan – the tribal 1,313 acre park contains a relatively natural landscape that includes two lakes, a diversity of natural habitats and cultural features and provide opportunities for a range of nature based outdoor recreational activities. The mission of the Park is “to preserve the Sky Chief Park’s natural and cultural heritage values.”
- TMBCI Fish Management Plan 2018-2028 - a comprehensive plan developed with the support of US. Fish & Wildlife and conducted by fish management specialist –Samuel Hultberg and Josh Wert. The plan is an essential guide in monitoring the numerous tribal lakes and waterways located within the Turtle Mountain Band of Chippewa Reservation.

### **Evaluation – Describe your plan to document progress and results.**

Please be specific on the methods you will utilize to measure success. Note that regular reporting, final evaluation and expenditure reports will be required for every grant awarded.

The Tribal Natural Resources Director (JJ) will assure that the tasks and activities of the project are accomplished in an efficient and timely manner. The Tribal Government has assigned Mr. Ron Trottier, District II Councilman, to be liaison with the NR team and to assure the needs of the tribe are addressed.

A quarterly and yearly progress report will be prepared by the NR Director who will in turn disseminate it to the tribal council and BIA for review and discussion. These reports will include the level of progress made toward project objectives, timelines, and measurable outcomes. They will also formulate the basis for reporting to the North Dakota Outdoor Heritage Fund.

## **Financial Information**

### **Project Budget – Use the table below to provide an itemized list of project expenses and describe the matching funds being utilized for this project.**

Indicate if the matching funds are in the form of cash, indirect costs or in-kind services. The budget should identify all other committed funding sources and the amount of funding from each source. **A**



**minimum of 25% match funding is required.** An application will be scored higher the greater the amount of match funding provided. (See Scoring Form.)

Certain values have been identified for in-kind services as detailed under “Budget Information” at the back of this form. Refer to that section and utilize these values in identifying your matching funds. **NOTE: No indirect costs will be funded. Supporting documentation for project expenses, including bids, must be included or application will be considered incomplete.**

Project Expense	OHF Request	Applicant's Match Share (Cash)	Applicant's Match Share (In-Kind)	Applicant's Match Share (Indirect)	Other Project Sponsor's Share	Total Each Project Expense
Fish/Boat Docks	\$ 117,000	\$	\$	\$	\$	\$ 117,000
Site Work	\$	\$	\$ 20,000	\$	\$	\$ 20,000
Concrete Work	\$	\$ 6,000	\$	\$	\$	\$ 6,000
Signage/Posts	\$	\$ 3,400	\$	\$	\$	\$ 3,400
	\$	\$	\$	\$	\$	\$
	\$	\$	\$	\$	\$	\$
<b>Total Costs</b>	<b>\$ 117,000</b>	<b>\$ 9,400</b>	<b>\$ 20,000</b>	<b>\$</b>	<b>\$</b>	<b>\$ 146,400</b>

Note: Costs for seeding, fencing, pipelines, wells, and cover crops cannot exceed NRCS Field Office Tech Guide without justification. Projects involving perimeter fencing must follow NRCS eligibility standards.

**Budget Narrative – Use the space below to provide additional detail regarding project expenses.**

Site Work (7 sites):	Shoreline Restoration \$5,000 Leveling and Fill \$10,000 Landscaping \$ 5,000	= \$20,000
Cement Walkways (2 Sites)	Concrete & manpower	= \$6,000
Signage/Posts (7 sites)	Materials & installation costs	= \$3,400
Fishing/Boat Docks (7 units)	Handicapped accessible w/railings 6' x 40' Portable dock walkway Aqua green Solar safety lights Seven units delivered and set up	= 117,000

**Sustainability – Indicate how the project will be funded or sustained in future years.**

Include information on the sustainability of this project after OHF funds have been expended and whether the sustainability will be in the form of ongoing management or additional funding from a different source.

Natural Resources Office will continually seek any funding opportunities afforded the tribe via federal, state, foundation, and private funding. This will involve having pro-active working relationships with a multitude of agencies and organizations – locally, statewide, and

nationally. The tribe is in the process of preparing a portfolio to complement its Work Plan and will be distributed to all potential funding agencies.

#### Recent leveraging:

- Conservation Law Enforcement Officers (CLEO) – to hire several Officers who will serve to enforce Fish and Wildlife codes and protect Natural Resources habitat areas on the reservation. The first year grant is funded for \$48,000 and is renewable in five-year increments.
- Portable Saw Mill Equipment and facility– to purchase portable saw mill equipment that will be used to make park structures such as cabins, picnic tables, signage, etc. A 32’ x 60’ foot metal building is currently being constructed to house the portable wood mill operation. Thus far, over \$500,000 has been committed to the project with tribal and BIA funds.
- Tribal Senior Program – to hire seniors ages 55 and over to assist with park maintenance including mowing grass, litter disposal, shoreline brushing, etc. Funded by BIA and the tribe in 2023 for 120,000.
  - Tribal Youth Program – to hire youth ages 14-18 to assist to work alongside seniors that was funded in 2023 for 60,000.
  - Belcourt Lake “Boy Scout Camp” development – the development of the sit with an investment of over \$300,000 for site development and addition of amenities such as docks, restroom, and picnic arbors. Funds were secured from the ND Outdoor Heritage Fund and the TMBC Tribal Government.
  - RV Park Development – the tribe has invested over \$30,000 for site development and engineering cost analysis to determine budget needed for installing water, sewer, & electrical power to the RV park site.
  - Greenhouse Lab – the NR department purchased and erected a greenhouse that will be used for engaging youth and elders in gardening and horticulture. The greenhouse is valued at \$20,000.

#### Pending projects

Sky Chief Park Stewardship Lodge: The TMBCI Tribal Government has recently authorized the Natural Resources Department to conduct a capital campaign for a \$2 million roundhouse facility to be used to host a multitude of educational stewardship activities. The NR Department will be headquartered within the lodge and will be equipped with the necessary technology equipment for video & web-based instructional delivery support.

Tribal Fishery Specialist – the tribe recently has obligated funds to hire a Fish & Wildlife Botanist to assist in studying the current status of the tribal lakes & waterways and recommend strategies for improvement.

TMBCI Tribal Marina/Bait Shop – the tribe is planning to conduct a feasibility study for the development and implementation of a tribal marina and bait shop to be housed at the Sky Chief Park. The tribe submitted a grant application to the National Fish & Wildlife Foundation for an “America the Beautiful” grant that will fund the feasibility as well as other fish management activities.

**Partial Funding – Indicate how the project will be affected if less funding is available than that requested.**

Any shortcomings in funding will be addressed by meeting with the Tribal Government to determine what tribal resources are available to meet the financial needs of the project. The tribe has been very committed to the Natural Resources Department in recognition of the vast amount of land and water that is its responsibility. It is a beautiful habitat that has nourished the TM Chippewa for generations and provided a wealth of recreational activities and programming.

It is essential the tribal government afford Native youth every opportunity to participate in natural resource educational and social programming to assure long term sustainability. Tribal members do not have to pay park entrance fees and almost all events initiated at the Belcourt lake complex is free to the public.

**Partnership Recognition - If you are a successful recipient of Outdoor Heritage Fund dollars, how would you recognize the Outdoor Heritage Fund partnership? \* *There must be signage at the location of the project acknowledging OHF funding when appropriate.***

The Turtle Mountain Band of Chippewa has access to all local media such as the Turtle Mountain Times & Turtle Mountain Star newspapers, tribal radio KEYA-FM radio, and social media such as facebook and you-tube. The tribe will take advantage of these opportunities and will assure that the ND Outdoor Heritage fund will receive recognition and promotional coverage within these media streams. A plaque recognizing all financial partners will be mounted at the entrance to each of the fishing/boat access dock sites.

**Awarding of Grants - Review the appropriate sample contract for your organization on the website at <http://www.nd.gov/ndic/outdoor-infopage.htm>.**

Can you meet all the provisions of the sample contract? X Yes  No

If there are provisions in that contract that your organization is unable to meet, please indicate below what those provisions would be:

## **ABOUT OHF:**

The purpose of the North Dakota Outdoor Heritage Fund is to provide funding to state agencies, tribal governments, political subdivisions, and nonprofit organizations, with higher priority given to projects that enhance **conservation** practices in this state by:

**Directive A.** Providing access to private and public lands for sportsmen, including projects that create fish and wildlife habitat and provide access for sportsmen;

**Directive B.** Improving, maintaining and restoring water quality, soil conditions, plant diversity, animal systems and by supporting other practices of stewardship to enhance farming and ranching;

**Directive C.** Developing, enhancing, conserving and restoring wildlife and fish habitat on private and public lands; and

**Directive D.** Conserving natural areas and creating other areas for recreation through the establishment and development of parks and other recreation areas.

## **EXEMPTIONS**

Outdoor Heritage Fund grants may not be used to finance the following:

- Litigation;
- Lobbying activities;
- Any activity that would interfere, disrupt, or prevent activities associated with surface coal mining operations; sand, gravel, or scoria extraction activities; oil and gas operations; or other energy facility or infrastructure development;
- The acquisition of land or to encumber any land for a term longer than twenty years; or
- Projects outside this state or projects that are beyond the scope of defined activities that fulfill the purposes of Chapter 54-17.8 of the North Dakota Century Code.

OHF funds may not be used, except after a finding of exceptional circumstances by the Industrial Commission, to finance:

- A completed project or project commenced before the grant application is submitted;
- A feasibility or research study;
- Maintenance costs;
- A paving project for a road or parking lot;
- A swimming pool or aquatic park;
- Personal property that is not affixed to the land;
- Playground equipment, except that grant funds may be provided for up to 25% of the cost of the equipment not exceeding \$10,000 per project and all playground equipment

grants may not exceed 5% of the total grants per year (see Definitions/Clarifications for how this will be calculated);

- Staffing or outside consultants except for costs for staffing or an outside consultant to design and implement an approved project based on the documented need of the applicant and the expenditures may not exceed 5% of the grant to a grantee if the grant exceeds \$250,000 and expenditures may not exceed 10% of the grant to a grantee if the grant is \$250,000 or less (see Definitions/Clarifications for how this will be calculated);
- A building except for a building that is included as part of a comprehensive conservation plan for a new or expanded recreational project (see Definitions/Clarifications for definition of comprehensive conservation plan and new or expanded recreational project); or
- A project in which the applicant is not directly involved in the execution and completion of the project.

The goal of the Industrial Commission is that at a minimum 15% of the funding received for a biennium will be given priority for recreation projects that meet Directive D.

The following projects are not eligible for funding, unless there is a finding of exceptional circumstances by the Industrial Commission include:

- Construction or refurbishment of indoor/outdoor ice rinks,
- Construction or refurbishment of indoor/outdoor athletic courts and sports fields,
- Other substantially similar facilities.
- Infrastructure that is not part of a comprehensive conservation plan.
- Projects not meeting a minimum funding request of \$2,500.

## **Budget Information**

In-kind services used to match the request for Outdoor Heritage Fund dollars shall be valued as follows:

- |                        |   |
|------------------------|---|
| • Labor costs          | \$15.00 an hour   |
| • Land costs           | Average rent costs for the county as shown in the most recent publication of the USDA, National Agricultural Statistics Services, North Dakota Field Office |
| • Permanent Equipment  | Any equipment purchased must be listed separately with documentation showing actual cost. (For example: playground equipment)                               |
| • Equipment usage      | Actual documentation  |
| • Seed & Seedlings     | Actual documentation  |
| • Transportation       | Mileage at federal rate   |
| • Supplies & materials | Actual documentation  |

More categories will be added as we better understand the types of applications that will be submitted. We will use as our basis for these standards other State and Federal programs that have established rates. For example, the North Dakota Nonpoint Source Pollution Management Program has established rates. If your project includes work that has an established rate under another State Program, please use those rates and note your source.

## **Definitions/Clarifications:**

**Building** - Defined as "A structure with a roof either with walls or without walls and is attached to the ground in a permanent nature."

Comprehensive Conservation Plan - Defined as “A detailed plan that has been formally adopted by the governing board which includes goals and objectives--both short and long term, must show how this building will enhance the overall conservation goals of the project and the protection or preservation of wildlife and fish habitat or natural areas.” This does not need to be a complex multi-page document. It could be included as a part of the application or be an attachment.

New and Expanded Recreational Project means that the proposed building cannot be a replacement of a current building. The proposed building must also be related to either a new or expanded recreational project--either an expansion in land or an expansion of an existing building or in the opportunities for recreation at the project site.

Playground equipment calculation - Only the actual costs of the playground equipment (a bid or invoice showing the amount of the equipment costs must be provided) - cannot include freight or installation or surface materials or removal of old equipment, etc.

Staffing/Outside Consultants Costs - If you are requesting OHF funding for staffing or for an outside consultant, you must provide information in your application on the need for OHF funding to cover these costs. For example, if you are an entity that has engineering staff you must explain why you don't have sufficient staff to do the work or if specific expertise is needed or whatever the reason is for your entity to retain an outside consultant. If it is a request for reimbursement for staff time then a written explanation is required in the application of why OHF funding is needed to pay for the costs of that staff member(s)' time. **The budget form must reflect on a separate line item the specific amount that is being requested for staffing and/or the hiring of an outside consultant.** This separate line item will then be used to make the calculation of 5% or 10% as outlined in the law. Note that the calculation will be made on the grant less the costs for the consultant or staff.

Maintenance – Activities that preserve or keep infrastructure in a given existing condition, including repairs. Repair means to restore to sound condition after damage, to renew or refresh; except repairs due to damage caused by Acts of God.

## Scoring of Grants

**Oral Presentation.** Please note that you will be given an opportunity to make a ten-minute Oral Presentation at a meeting of the Outdoor Heritage Fund Advisory Board. These presentations are strongly encouraged.

**Open Record.** Please note that your application and any attachments will be open records as defined by law and will be posted on the Industrial Commission/Outdoor Heritage Fund website.

All applications will be scored by the Outdoor Heritage Fund Advisory Board after your ten-minute oral presentation. The ranking form that will be used by the Board is available on the website at <http://www.nd.gov/ndic/outdoor-infopage.htm> .

## Awarding of Grants

All decisions on requests will be reported to applicants no later than 30 days after Industrial Commission consideration. The Commission can set a limit on duration of an offer on each application or if there isn't a specific date indicated in the application for implementation of the project, then the applicant has until the next Outdoor Heritage Fund Advisory Board regular meeting to sign the contract and get the project underway or the commitment for funding will

be terminated and the applicant may resubmit for funding. Applicants whose proposals have been approved will receive a contract outlining the terms and conditions of the grant.

## **Responsibility of Recipient**

The recipient of any grant from the Industrial Commission must use the funds awarded for the specific purpose described in the grant application and in accordance with the contract. The recipient cannot use any of the funds for the purposes stated under Exemptions on the first page of this application.

If you have any questions about the application, the Commission can be reached at 701-328-3722 or [outdoorheritage@nd.gov](mailto:outdoorheritage@nd.gov).

Revised: November 4, 2019, April 12, 2023

# CTI METAL WORKS

PO BOX 900 HWY 5 WEST  
4162 US HWY 281  
BELCOURT ND 58316

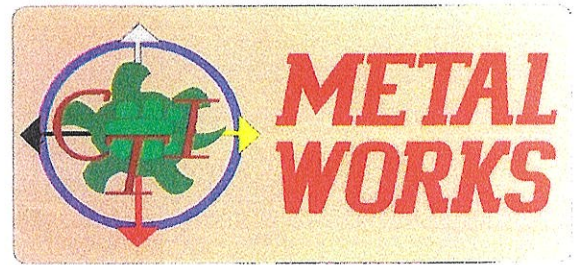

QUOTE

### BILL TO

Turtle Mountain Tribe  
Department of Natural Resources  
PO Box 900  
Belcourt, ND 58316

### SHIP TO

Quote Date: 09/6/2023  
Valid For: 30 days

DESCRIPTION	QTY	UNIT PRICE	TOTAL
5' X 40' Boat Dock with accessories	1		15800.00
Adjustable legs flow through decking			0.00
Miscellaneous Hardware			0.00
Marine Paint and Primer			0.00
<b>5' X 40' Total</b>			0.00
			0.00
			0.00
			0.00
			0.00
Delivery and Set-up			1000.00
			0.00
		<b>SUBTOTAL</b>	16800.00
		<b>DISCOUNT</b>	0.00
		<b>SUBTOTAL LESS DISCOUNT</b>	16800.00
		<b>TAX RATE</b>	0.00%
		<b>TOTAL TAX</b>	0.00
		<b>SHIPPING/HANDLING</b>	0.00
		<b>Quote Total</b>	<b>\$ 16,800.00</b>

Thank you for your business!

### Terms & Instructions

Payment terms: 50% Down Payment. Please provide balance within 30 days of completion.

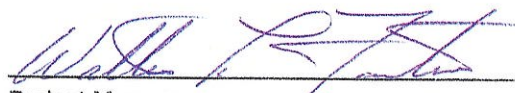
  
Project Manager

9-6-23  
Date

\_\_\_\_\_  
Approved By

\_\_\_\_\_  
Job Title



REVISIONS

No.	Description	Date	Init.

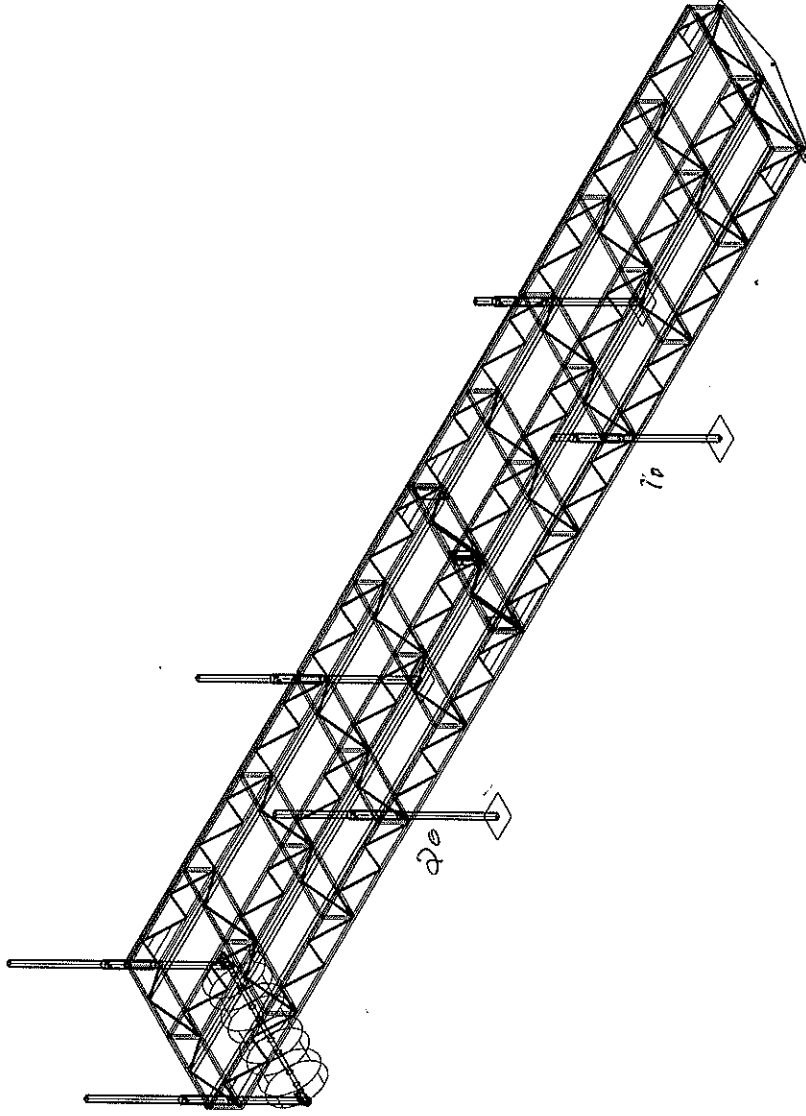

Part Tolerances: .00: +/- 0.03 .000: +/- 0.015 ANGLES: +/- 1 DEG	CTI METALWORKS ASSOCIATES Hwy. 5 West, Belcourt ND 58316		
Part Name: 6' X 40' BOATING DOCK	Drawing No: MWDA4000	Cad No: MWDA4000.PRT	
Material: N/A	Project: MWDA4000	Sheet No: 01 of 01	
Date: 09-02-2022 Drawing By: R.E.G.	Apprd By:	Scale: 1.0=.03	

**Turtle Mountain Band of Chippewa  
2018-2028 Management Plan**

**Samuel Hultberg and Josh Wert  
U.S. Fish & Wildlife Service  
Missouri River FWCO  
3425 Miriam Ave.  
Bismarck, ND 58501  
701-355-8576**

**Table of Contents**

I.	<b>Introduction</b>	<b>1</b>
II.	<b>History</b>	<b>2</b>
III.	<b>Definition of Terms</b>	<b>3</b>
IV.	<b>Belcourt (Fish) Lake</b>	<b>4</b>
	<b>A. Inventory</b>	<b>4</b>
	<b>B. Development</b>	<b>5</b>
	<b>C. Fishery</b>	<b>5</b>
	<b>D. History of Management Actions</b>	<b>9</b>
	<b>E. Management Problems</b>	<b>9</b>
	<b>F. Management Goals and Objectives</b>	<b>10</b>
	<b>G. Proposed Management Actions</b>	<b>11</b>
	<b>H. Evaluation of Management Actions</b>	<b>11</b>
	<b>I. Other Management Options Considered</b>	<b>12</b>
	<b>J. Projected Time Frame</b>	<b>12</b>
	<b>K. Literature Cited</b>	<b>12</b>
V.	<b>Gordon Lake</b>	<b>13</b>
	<b>A. Inventory</b>	<b>14</b>
	<b>B. Development</b>	<b>14</b>
	<b>C. Fishery</b>	<b>18</b>
	<b>D. History of Management Actions</b>	<b>18</b>
	<b>E. Management Problems</b>	<b>19</b>
	<b>F. Management Goals and Objectives</b>	<b>19</b>
	<b>G. Proposed Management Actions</b>	<b>20</b>
	<b>H. Evaluation of Management Actions</b>	<b>20</b>
	<b>I. Other Management Options Considered</b>	<b>20</b>
	<b>J. Projected Time Frame</b>	<b>20</b>
	<b>K. Literature Cited</b>	<b>20</b>
VI.	<b>Wheaton Lake</b>	<b>21</b>
	<b>A. Inventory</b>	<b>22</b>
	<b>B. Development</b>	<b>22</b>
	<b>C. Fishery</b>	<b>25</b>
	<b>D. History of Management Actions</b>	<b>25</b>
	<b>E. Management Problems</b>	<b>25</b>
	<b>F. Management Goals and Objectives</b>	<b>26</b>
	<b>G. Proposed Management Actions</b>	<b>27</b>
	<b>H. Evaluation of Management Actions</b>	<b>27</b>
	<b>I. Other Management Options Considered</b>	<b>27</b>
	<b>J. Projected Time Frame</b>	<b>27</b>
	<b>K. Literature Cited</b>	<b>27</b>

VII.	<b>Jarvis Lake</b>	<b>28</b>
	<b>A. Inventory</b>	<b>29</b>
	<b>B. Development</b>	<b>29</b>
	<b>C. Fishery</b>	<b>34</b>
	<b>D. History of Management Actions</b>	<b>34</b>
	<b>E. Management Problems</b>	<b>35</b>
	<b>F. Management Goals and Objectives</b>	<b>35</b>
	<b>G. Proposed Management Actions</b>	<b>36</b>
	<b>H. Evaluation of Management Actions</b>	<b>36</b>
	<b>I. Other Management Options Considered</b>	<b>36</b>
	<b>J. Projected Time Frame</b>	<b>36</b>
	<b>K. Literature Cited</b>	<b>36</b>
VIII.	<b>Martin Lake</b>	<b>37</b>
	<b>A. Inventory</b>	<b>38</b>
	<b>B. Development</b>	<b>38</b>
	<b>C. Fishery</b>	<b>39</b>
	<b>D. History of Management Actions</b>	<b>40</b>
	<b>E. Management Problems</b>	<b>40</b>
	<b>F. Management Goals and Objectives</b>	<b>41</b>
	<b>G. Proposed Management Actions</b>	<b>41</b>
	<b>H. Evaluation of Management Actions</b>	<b>41</b>
	<b>I. Other Management Options Considered</b>	<b>41</b>
	<b>J. Projected Time Frame</b>	<b>41</b>
	<b>K. Literature Cited</b>	<b>42</b>
IX.	<b>Crow Lake</b>	<b>43</b>
	<b>A. Inventory</b>	<b>44</b>
	<b>B. Development</b>	<b>44</b>
	<b>C. Fishery</b>	<b>45</b>
	<b>D. History of Management Actions</b>	<b>45</b>
	<b>E. Management Problems</b>	<b>46</b>
	<b>F. Management Goals and Objectives</b>	<b>46</b>
	<b>G. Proposed Management Actions</b>	<b>47</b>
	<b>H. Evaluation of Management Actions</b>	<b>47</b>
	<b>I. Other Management Options Considered</b>	<b>47</b>
	<b>J. Projected Time Frame</b>	<b>47</b>
	<b>K. Literature Cited</b>	<b>47</b>

## I. **Introduction**

The Turtle Mountain Band of Chippewa Natural Resources Division (TMNRD) has taken an active role in the monitoring of fish communities from lakes found within the boundaries of the Turtle Mountain Reservation. Fish community data used for estimating population abundance occur annually. The data collected will determine management decisions at each lake.

Though the TMNRD is responsible for coordinating overall efforts for managing reservation and other jurisdictional lakes, the department recognizes that many agencies, organizations, and individuals have a role in assisting with management practices. The federal government has an ongoing relationship with federally recognized Native American Tribes and plays a key role in developing management plans and assisting with data collection. Treaties, statutes, executive orders, judicial decisions, define the relationship between the federal government and each tribe, and agreements not found within state and local governments. With collaboration between the federal and tribal conservation offices, conservation efforts can effectively conserve fish, wildlife, plants, and their habitats.

Aquatic resources are fundamental building blocks of all ecosystems. They provide essential ecological processes in which terrestrial ecosystems depend on. Inconsistent management has been a problem associated with the aquatic resources on the Turtle Mountain Reservation. Annual data collection is necessary to ensure aquatic resources are healthy. Like many North American fisheries, threats to aquatic resources include loss of habitat, degradation of water quality, exotic species introduction, poor land use and watershed planning, and introductions of pesticides and other pollutants.

Long-term sustainability of these fisheries will depend on the ability to recognize, evaluate, correct, and monitor these problems.

## II. **History**

The Turtle Mountain Reservation is in the Turtle Mountain geographical area of north central North Dakota of Rolette County. The land found within the Turtle Mountains formed by erosion and glacial deposition. Glacial ice once covered the entire area and once that ice began to recede, large debris deposited to form the Turtle Mountains. Within these deposits, the glacier carved many shallow lakes and wetlands that sculpted the rolling hills and ravines in which streams flowed.

These carved out glacial lakes produce some unique recreational opportunities within the state of North Dakota. Among the many lakes that are found within the Turtle Mountains, the lakes that are most commonly fished on the reservation are the natural lakes of Jarvis and Wheaton and the two impounded reservoirs of Gordon and Belcourt (Fish). Stocking, by the U.S. Fish and Wildlife Service, has been ongoing to help support a recreational fishery. There are also many smaller lakes in the area known to support natural populations of fish including yellow perch and northern pike.

In 2002, the Turtle Mountain Tribal Council passed into legislation, the first ever comprehensive Game and Fish Code. This code serves to regulate hunting and fishing activities within tribal jurisdiction. These regulations allow the tribe to assume greater control over the planning and implementation of game and fisheries activities, which include the development of management strategies for its aquatic resources.

### III. Definition of Terms

- **N** – All the individuals of the same species within a defined geographic location at a given time.
- **CPUE – Catch per Unit Effort** – The number or weight of organisms captured with a defined unit of sampling or fishing effort.
- **Population Abundance** – Biomass or numbers of individuals in a population, a portion of the population (such as a year-class), or a sample.
- **WPUE – Weight per Unit Effort** – An indirect measure of the weight of a target species. Changes in the weight per unit effort infers a change to the target species' true weight.
- **Mean Length** – The average length of the target species.
- **Mean Weight** – The average weight of the target species.
- **Wr – Relative Weight** – An index of condition calculated by dividing the weight of a fish by a length-specific standard weight for that species.
- **Avg. Wr** – The average relative weight of the target species.
- **PSD – Proportional Stock Density** – The percentage of a sample of “stock-length” fish that also are greater than or equal to “quality length.” Stock and quality lengths are species-specific.
- **RSD – Relative Stock Density** – The percentage of “stock-length” fish that also are in a defined length interval of larger fish. Stock lengths and larger length-classes (“quality,” “preferred,” “memorable,” and “trophy”) are species-specific.

#### IV. Belcourt (Fish) Lake

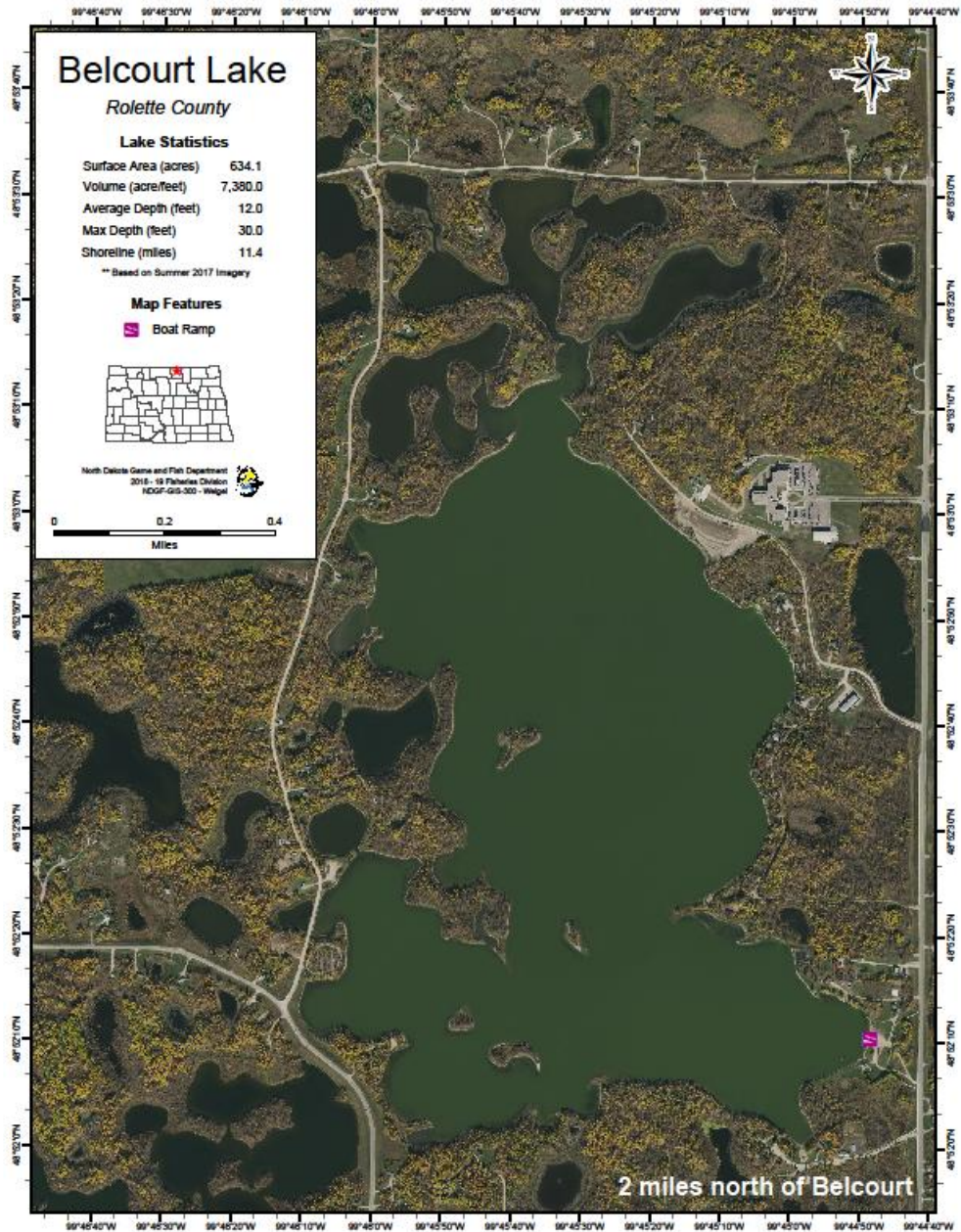

**Figure 1:** Belcourt Lake found 2 miles north of Belcourt, ND. Picture taken for the ND Game and Fish Website.

#### A. Inventory

1. **Legal Description:** Township 162 N, Range 70 W, Sections 5, 6, 7, and 8.
2. **Location to nearest town:** Approximately 1.5 miles north of Belcourt, ND.
3. **Ownership:** Considered federal waters by virtue of its location within the exterior boundaries of the Turtle Mountain Band of Chippewa Reservation. Management of the lake lies primarily with the Turtle Mountain Band of Chippewa with trust oversight by the Bureau of Indian Affairs (USDOJ).



4. **Type:** Reservoir
5. **Size:** 633.9 Surface Acres
6. **Elevation:** Average elevation is 2010 feet amsl
7. **Maximum Depth:** 30 feet **Average Depth:** 12 feet
8. **Volume:** 7380 acre-feet of water at max height (2,404,773,000 gallons)
9. **Shoreline miles:** 4.10 miles
10. **Priority Score:** Tier 3
11. **Lake Assessment:** None as of 2018
12. **Watershed Size:** Not determined
13. **Location of normal outlet:** Southeast corner of lake at spillway
14. **Littoral area:** 0-16 feet from shoreline

**B. Development**

1. Belcourt Lake has two boat ramps for recreational use. Slater’s Beach (SE corner) has a single poured concrete slab ramp that is accessible with higher water levels. Red Bear point (W shore) also has a ramp that is useable during low water levels. The Bureau of Indian Affairs places a dock adjacent to the boat ramp and Slater’s Beach. Lighting is also available at Slater’s Beach that consists of a street light that illuminates with the onset of dusk. No fish cleaning facilities exist.

**C. Fishery**

1. General Description

- a. Belcourt Lake is a reservoir created by the impoundment of Ox Creek. The dam structure consists of an earthen embankment with a concrete primary spillway. Primary control of the spillway is by a series of floodgates that regulate flow. Original creation of Belcourt Lake was for a municipal water source for the reservation. Modern use is for recreation and flood control. Dam and spillway maintenance was conducted in 2018 (**More information needed**).

2. Species List

**Table 1:** Fish species found in Belcourt Lake.

<b>Common</b>	<b>Uncommon</b>	<b>Undesired</b>
walleye - S	bluegill - NR	black bullhead
northern pike - NR	black crappie	
yellow perch - NR	fathead minnow - NR	
S- denotes stocked		
NR – denotes natural reproduction		

3. Population Status and Trends

a. **Walleye** – Walleye introductions began in 1930 with intermittent stocking since then. Since 2000, walleye stocking occurred every year (except 2012 and 2013). During these years, walleye stock rates ranged from 31 to 63 fingerlings per acre. High nutrient loading has an impact on walleye natural reproduction. There does not appear to be any natural reproduction of walleye occurring in Belcourt Lake.

Dissolved oxygen levels, in the winter of 2017, were extremely low causing a significant walleye winterkill. Data collected in the summer of 2018 had zero walleye captures. Walleye stocking occurred early in the summer of 2018 in an effort of reintroduction. It will take a few years for the population to bounce back barring reoccurring winterkill.

b. **Northern pike** – Northern pike introductions began in 1952 with intermittent stocking since then. Currently, natural reproduction sustains northern pike populations. Northern pike catch rates have varied from three to six fish/net-night (Table 2) during adult population sampling in 2017 and 2018. Based on proportional stock densities, there are more northern pike in the preferred to memorable range (56%) on average in 2017 and 2018. There is also a large percentage in the quality to preferred range (29.5%) in 2017 and 2018.

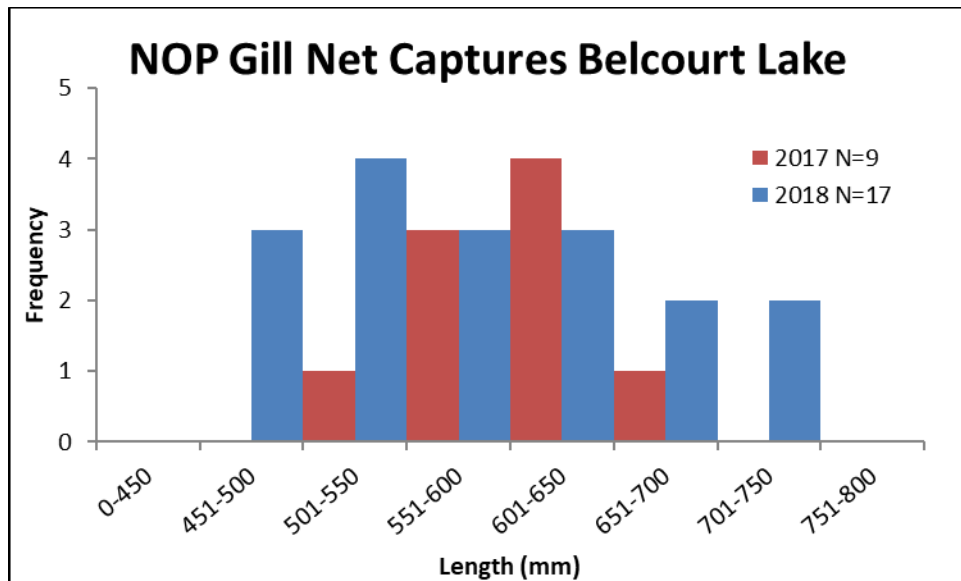

**Figure 1:** Length frequency histogram of northern pike found in Belcourt Lake from 2017 to 2018.

- c. **Yellow perch** – Yellow perch introductions began in 1942 with intermittent stocking since then. Currently, natural reproduction sustains yellow perch populations. Yellow perch catch rates have remained constant in 2017 and 2018 with captures varying from 13 to 15 fish/net-night (Table 2). Based on proportional stock densities, there are more yellow perch in the stock to quality range (68.5%) on average in 2017 and 2018. There are also some larger quality to preferred fish (25%) on average in 2017 and 2018. Yellow perch growth rates appear to slow down when they reach lengths between 170 and 200 mm. Therefore, yellow perch management is as a forage fish with very few high quality yellow perch in the population.

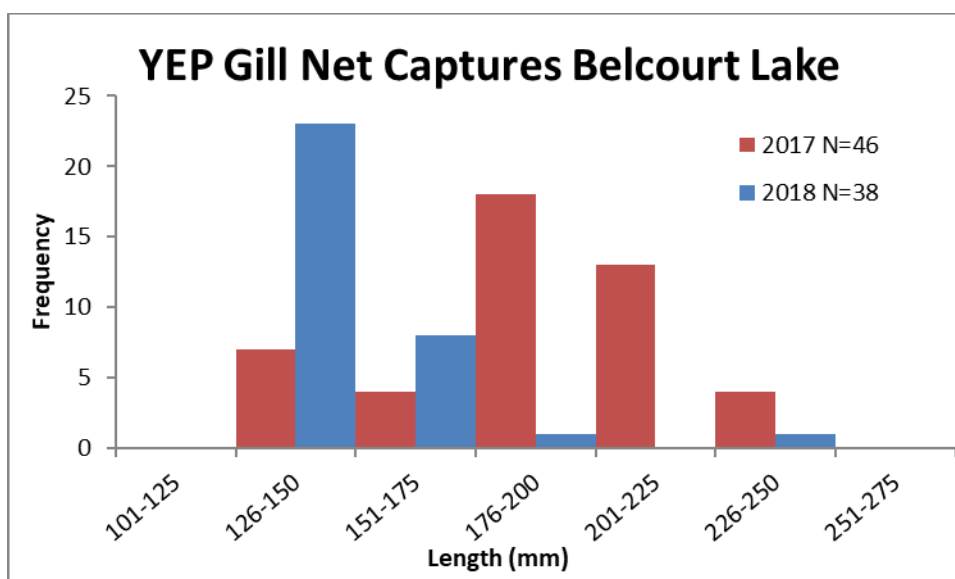

**Figure 2:** Length frequency histogram of yellow perch found in Belcourt Lake from 2017 to 2018.

- d. **Bluegill** – Bluegill introductions began in 1945 with zero fish stocked in the past 7 years. One adult bluegill capture occurred in 2017 with zero captures in 2018. Currently the bluegill population is at a low abundance, which might have to do with a partial winterkill in winter of 2017 and with the high abundance of black bullheads in the system.

**Table 2:** Population trend – 6’ x 125’ x 3/4” – 2” gill nets in Belcourt Lake in 2017 and 2018.

Target Species		2017	2018	Mean
Walleye	N	26	0	13
	CPUE (#/net-night)	8.7	0	4.35
	WPUE	8764	0	4382
	Mean Length (mm)	483	0	241.5
	Mean Weight (g)	1198	0	599
	Avg Wr	93.06	0	46.53
	PSD	12	0	6
	RSD S-Q	0	0	0
	RSD Q-P	12	0	6
	RSD P-M	46	0	23
	RSD M-T	42	0	21
		2017	2018	Mean
Northern pike	N	9	17	13
	CPUE (#/net-night)	3	5.7	4.35
	WPUE	4196.7	6954	5575.35
	Mean Length (mm)	609	592	600.5
	Mean Weight (g)	1398	1304	1351
	Avg Wr	93.06	96.3	94.68
	PSD	0	10	5
	RSD S-Q	0	29	14.5
	RSD Q-P	0	59	29.5
	RSD P-M	100	12	56
	RSD M-T	0	0	0
		2017	2018	Mean
Yellow perch	N	46	38	42
	CPUE (#/net-night)	15	12.7	13.85
	WPUE	1494	568	1031
	Mean Length (mm)	192	152	172
	Mean Weight (g)	97.4	97.4	97.4
	Avg Wr	94	109	101.5
	PSD	47	3	25
	RSD S-Q	50	87	68.5
	RSD Q-P	47	3	25
	RSD P-M	2	0	1

4. History of Angler Use

- a. The most desired species, by anglers, include walleye, northern pike, yellow perch, and bluegill. These are the species that are most sought after during all seasons. Based on population assessments, natural reproduction appears to be limited with walleye. Populations of these fish have remained constant with annual stocking and management measures. With a high nutrient load, Belcourt Lake is susceptible to periodic winterkill.

## **D. History of Management Actions**

1. Eradications
  - a. The most undesirable species found in Belcourt Lake is the black bullhead. Steps taken to remove this species has been shallow netting measures undertaken by the EPA Department. Local anglers also aid in removal through individual measures. Black bullheads compete for the same resources that desired game species use. Black bullhead removal conducted throughout the sampling season.
2. Dam Reconstruction
  - a. Summer of 2018 – (More information needed)
3. Stocking
  - a. The N.D. Game and Fish and the U.S. Fish and Wildlife Service provide stocking information. Walleye, bluegill, northern pike, yellow perch, black crapping, smallmouth bass, channel catfish, largemouth bass, and rainbow trout stockings have occurred historically.
4. Special Regulations –
  - a. More information needed

## **E. Management Problems**

1. Physical/Chemical
  - a. Belcourt Lake suffers from a high nutrient load in the watershed that connects Wheaton Lake, Gordon Lake, and Belcourt Lake. Phosphorous and nitrogen are two common nutrients that are found naturally in sediment released by decomposing plant matter. In balanced levels, these nutrients can help aquatic ecosystems thrive. Chronic nutrient loading can lead to water quality issues that affect Belcourt Lake. Excess nutrient loads can cause undesired algae blooms that can cause fish kills.

The Turtle Mountain Band of Chippewa have collect water quality measurements since 2001. They requested the assistance of Houston Engineering, Inc. to identify the impacts of high nutrient loading in the Belcourt Lake watershed. Sources of this phosphorous loading includes Surface water runoff, atmospheric deposition, septic system loading, and discharge from upstream lakes.

The information collected will be useful in developing water quality goals, establish nutrient loading capacities, and provide a basis to improve management of the Belcourt Lake watershed.

2. Development
  - a. Facilities – Talk with the Turtle Mountain Department of Natural Resources and N.D. Game and Fish about piers, boat ramps, docks, lights, fish cleaning stations, etc.

- b. Enhancement – None
- 3. Fishery
  - a. With Belcourt Lake being highly susceptible to winterkill, populations will need monitoring to ensure they are sustainable.
  - b. Yellow perch continue to be small and it is unlikely that Belcourt Lake will produce quality-sized perch.
  - c. Black bullheads have been a continuous problem.
- 4. Sociological
  - a. Anglers have an unrealistic expectation of the quality of perch and walleye Belcourt Lake can produce.

**F. Management Goals and Objectives**

- 1. Goal
  - a. To maintain Belcourt Lake as a rustic, secluded, multi-purpose, recreational lake that provides the local community with a quality outdoor experience.
- 2. Objectives
  - a. To meet the management goal by maintaining a diverse quality sport fishery for walleye, yellow perch, northern pike, and bluegill.

**Table 3:** Accepted stock density index ranges for balanced fish populations. Target values by sampling effort and species should equal or exceed ranges.

<b>Species</b>	<b>Capture Rate</b>	<b>Wr</b>	<b>PSD</b>
walleye	10 fish/net-night	90	30-60
northern pike	5 fish/net-night	90	30-60
bluegill	10 fish/net-night	90	20-60
yellow perch	10 fish/net-night	90	30-60

- b. Improve habitat for desired species.
- c. Upgrade the capacity of the Turtle Mountain Department of Natural Resources to allow for improved monitoring and maintenance actions.
- d. To decrease the number of black bullhead currently in the system.
- e. Develop basic facilities and amenities to increase use of Belcourt Lake during summer months.

## **G. Proposed Management Actions**

### **1. Physical/Chemical**

- a. Reduce the current nutrient load in Belcourt Lake. Vegetative buffer zones can be effective at capturing excess nutrients on a waterbody. These buffers can extend 3-5 feet around the shoreline and around drainage areas.
- b. Another option would be to introduce an aeration system that increases dissolved oxygen. This would increase the activity of aerobic bacteria that would deter the growth of unwanted algae blooms.
- c. Stabilize water levels throughout the year. With the installation of box culverts below the spillway, excess spring runoff should be controllable. With stabilized water levels, the shoreline of Belcourt will not slump and erode into the lake.
- d. Bank stabilization will need implementing to prevent further erosion of the shoreline.
- e. To help control the black bullhead population, fishing tournaments that specifically target black bullheads would be a good option. This would be a great outreach opportunity to increase public awareness of the bullhead problem.

### **2. Development**

- a. Discuss development opportunities with the Department of Natural Resources

### **3. Fishery**

- a. Stocking of walleye (even years) and bluegill (odd years) will occur on an alternate year basis. Stocking rates will be dependent on the current population trends. There are no plans for introducing new species.

### **4. Sociological**

- a. Regulations – Talk to the department about current regulations on fish limits.
- b. Information/Education – Information kiosks and signs posted at each boat ramp will inform the public on current regulations and management problems.
- c. Interagency Communication – Coordinate with the Turtle Mountain Department of Natural Resources on sampling dates and data collected.

## **H. Evaluation of Management Actions**

### **1. Evaluation Design**

- a. Summer population surveys will need to occur annually. These surveys will provide important information on population dynamics, size structure, relative abundance, condition, and reproductive success. The data collected will influence management decisions.

- b. Water quality measurements are crucial and taken periodically during late summer and mid-winter.

**I. Other Management Options Considered**

- 1. **Ideas?**

**J. Projected Time Frame**

January-February	Conduct winter water quality sampling
June	Conduct summer population sampling
July-August	Conduct summer water quality sampling

**K. Literature Cited**

- Carlander, K., Whitney, R., Speaker, E., and Madden, K. Evaluation of Walleye Fry Stocking in Clear Lake, Iowa, by Alternate-Year Planting. Transactions of the American Fisheries Society, Vol. 89, 3, pp 249-254 (1960).
- Murphy, B. and Willis, D. *Fisheries Techniques Second Edition*. (1996)
- Nielsen, L. and Johnson, D. *Fisheries Techniques*. (1989)
- Osborne, L. and Kovacic, D. Riparian vegetated buffer strips in water-quality restoration and stream management. *Freshwater Biology*, 29, pp 243-258 (1993).



## V. Gordon Lake

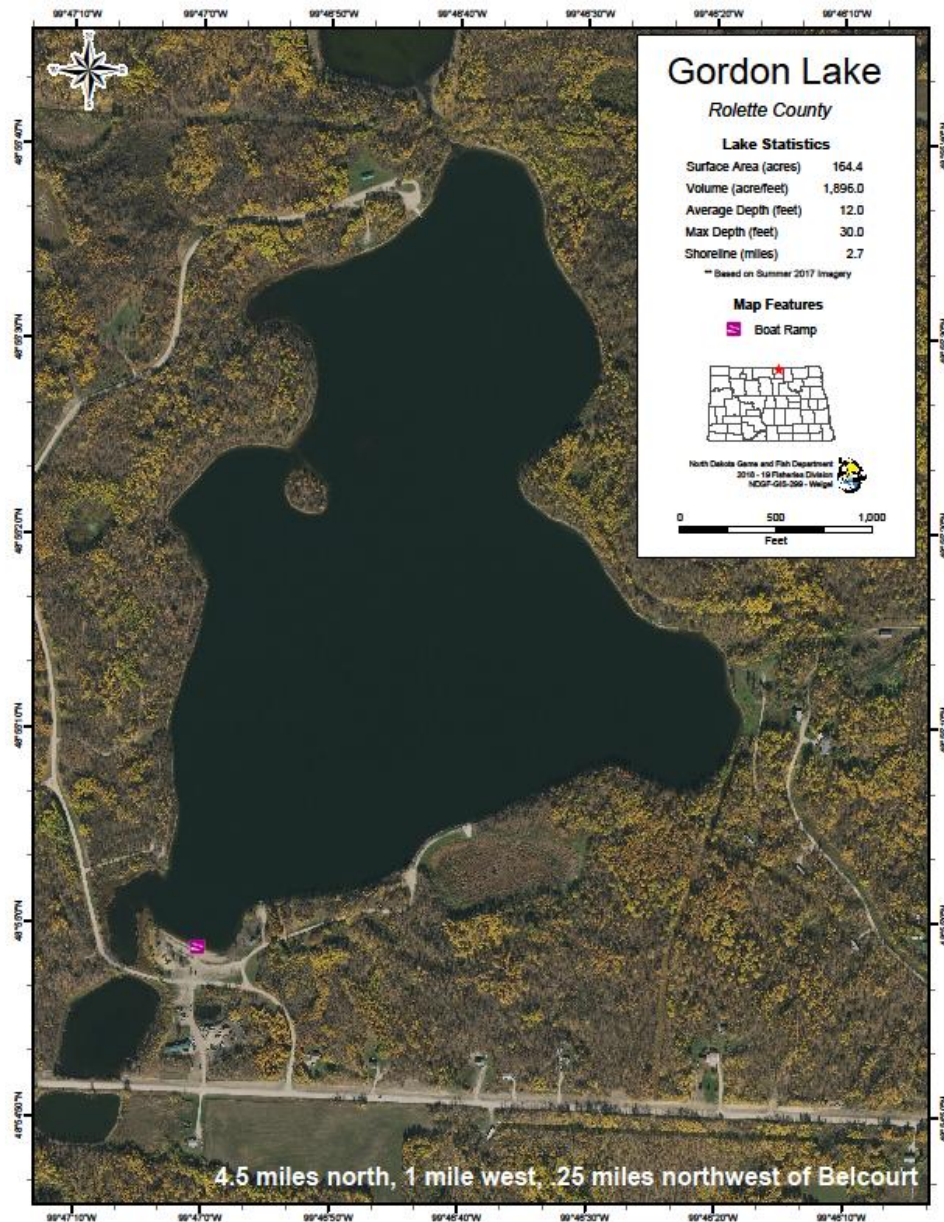

**Figure 2:** Gordon Lake located 4.5 miles north and 1 mile west of Belcourt, ND. Picture taken from the ND Game and Fish website.

### A. Inventory

1. **Legal Description:** Township 163N, Range 70W, sections 30 and 19.
2. **Location to nearest town:** 4.5 miles north, 1 mile west, .25 miles northwest of Belcourt
3. **Ownership:** Considered federal waters by virtue of its location within the exterior boundaries of the Turtle Mountain Band of Chippewa Reservation. Management of the lake lies primarily with the Turtle Mountain Band of Chippewa with trust oversight by the Bureau of Indian Affairs (USDOJ).

4. **Type:** Gordon Lake is a reservoir created by the impoundment of an unnamed creek. The dam structure consists of an earthen embankment with an earthen primary spillway. This spillway is uncontrolled and is for emergency overflows only. Original creation of Gordon Lake was for recreation completed during the Civilian Conservation Corps era. Modern use if for recreation and flood control.
5. **Size:** 158 surface acres
6. **Elevation:** 2090 feet amsl
7. **Maximum Depth:** 25-35 feet **Average Depth:** 12 feet
8. **Volume:** 1896 acre-feet
9. **Shoreline miles:** 0.90 miles
10. **Priority Score:** Tier 4
11. **Lake Assessment:** None as of 2018
12. **Watershed Size:** Has not been formally determined
13. **Location of normal outlet:** The primary outlet is located at the southern end of the lake (NW4, NE4, Section 30 T163N R70W) at its principal spillway.
14. **Littoral area:** 0-15 feet from shore

**B. Development**

1. Gordon Lake has a boat ramp for recreational use on the north part of the lake. There is a single poured concrete slab ramp with a dock placed adjacent to the ramp by the Bureau of Indian Affairs. Lighting is available near the boat ramp with the onset of dusk. Gordon Lake also has limited, rustic camping areas along the western and northern shores. There is no fish cleaning facility on the lake. Near the boat ramp, there is also a picnic shelter.

**C. Fishery**

1. General Description
  - a. Gordon Lake is a reservoir created by the impoundment of an unnamed creek. The dam structure consists of an earthen embankment with an earthen primary spillway. This spillway is uncontrolled and is for emergency overflows only. Original creation of Gordon Lake was for recreation and completed during the Civilian Conservation Corps era. Modern use is for recreation and flood control.
2. Species List

**Table 4:** Fish species found in Gordon Lake.

<b>Common</b>	<b>Uncommon</b>
walleye - S	bluegill - NR
northern pike - NR	fathead minnow - NR
yellow perch - NR	

S - denotes stocked  
NR – denotes naturally reproduction

3. Population Status and Trends

- a. **Walleye** – Walleye introductions began in 1910 with intermittent stocking since then. Since 2003, walleye stocking occurred each year (except 2011, 2012, and 2013) at rates ranging from 32 to 99 fingerlings per acre. There does not appear to be natural reproduction occurring in Gordon Lake.

Relative weights of walleye have remained steady ( $Wr$ 's = 84.9 to 91) in the past decade. Walleye catch rates have varied from eight to 18 fish/net-night in the past decade. Based on proportional stock densities, there are more walleye in the preferred to memorable (42.7%) range on average in the past decade. There is also a high percentage of fish (on average) in the standard to quality (27.7%) range (Table 4). The population appears to be healthy, with many year classes present.

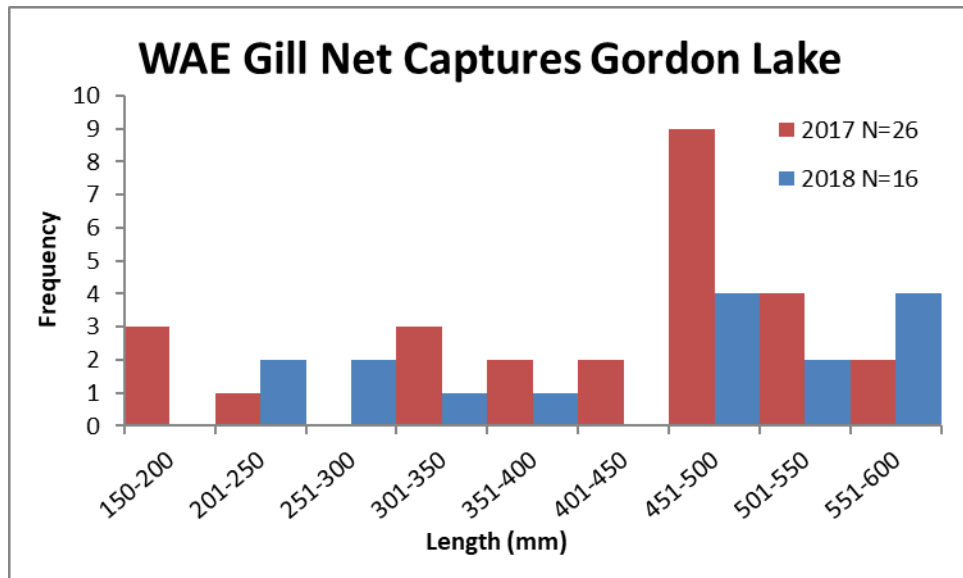

**Figure 3:** Length frequency histogram of walleye found in Gordon Lake from 2017 to 2018.

- b. **Northern pike** – Northern pike introductions began in 1940 with intermittent stocking since then. Northern pike stockings have not occurred 1998. Currently, natural reproduction sustains northern pike populations. Northern pike catch rates have varied from four to 10 fish/net-night in the past decade. Based on proportional stock densities, there are more fish found in the standard to quality (50.3%) range on average (Table 4) from the past decade

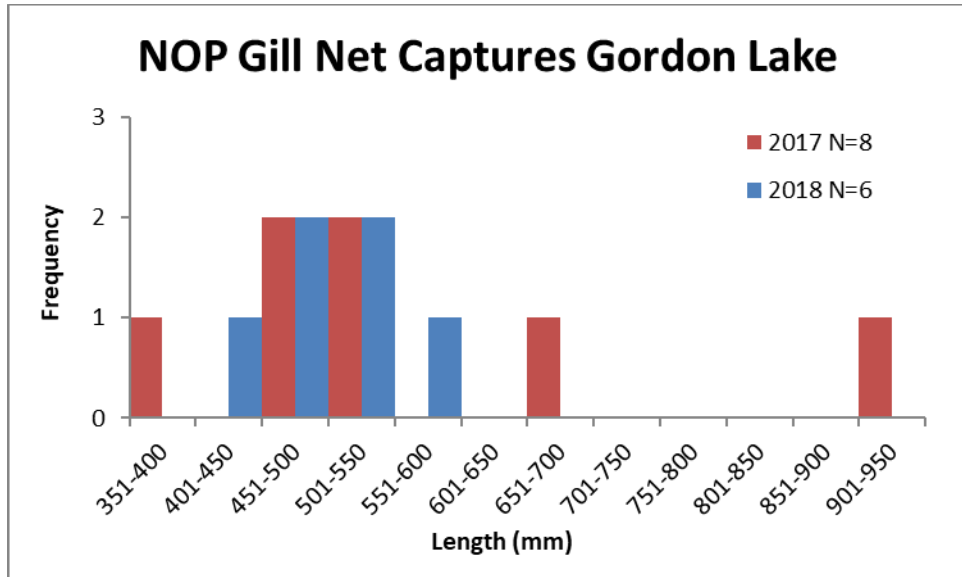

**Figure 4:** Length frequency histogram of northern pike found in Gordon Lake from 2017 to 2018.

- c. **Yellow perch** – Yellow perch introductions began in 1929 with intermittent stocking since then. Yellow perch stocking has not occurred since 1998. Currently, natural reproduction sustains yellow perch populations. Yellow perch catch rates have varied from six to 23 fish/net-night in the past decade. Based on proportional stock densities, yellow perch populations are comprised mainly of standard to quality (73%) sized fish (Table 4). Growth rates of yellow perch appear to slow between 130 and 200 millimeters with quality to preferred (30.7%) fish captured on average. Yellow perch management is as a forage fish for walleye and northern pike.

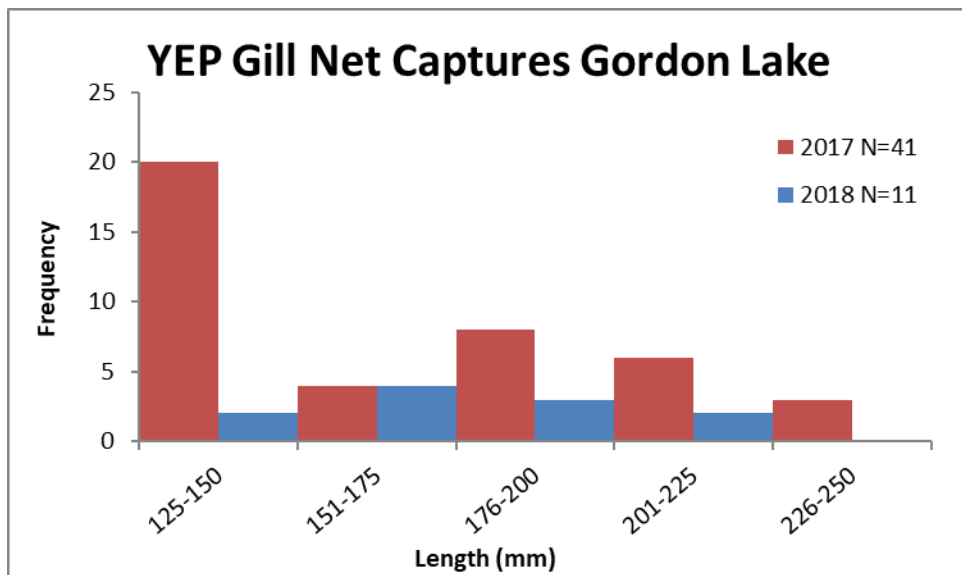

**Figure 5:** Length frequency histogram of yellow perch found in Gordon Lake from 2017 to 2018.

- d. **Bluegill** – Bluegill introductions began in 1929 with intermittent stocking since then. Since 2003, bluegill stock rates ranged from 50 to 297 fingerlings per acre. Currently, natural reproduction is maintaining bluegill populations. Gill nets are inefficient at capturing bluegill, with all bluegill captures occurring in trap nets. Trap net captures are primarily composed of small bluegill, which offer a forage for walleye and northern pike.

**Table 5:** Population trend – 6' x 125' x ¾"-2" gill nets in Gordon Lake from 2011 to 2018.

Target Species		2011	2017	2018	Mean
Walleye	N	36	26	16	26
	CPUE (#/net-night)	18	13	8	13
	WPUE	13363.5	16275.5	10104	13247.7
	Mean Length (mm)	409	480	488.8	459.3
	Mean Weight (g)	742	1252	1263	1085.7
	Avg Wr	87	91	84.9	87.6
	PSD	39	23	13	25
	RSD S-Q	39	19	25	27.7
	RSD Q-P	39	23	13	25
	RSD P-M	22	50	56	42.7
	RSD M-T	0	8	6	4.7
		2011	2017	2018	Mean
Northern pike	N	14	8	20	14
	CPUE (#/net-night)	7	4	10	17
	WPUE	4141	5095.5	8604.5	5947
	Mean Length (mm)	451	541	542	511.3
	Mean Weight (g)	592	1273	905.7	923.6
	Avg Wr	97.3	95.8	92.1	95.1
	PSD	14	25	55	31.3
	RSD S-Q	43	63	45	50.3
	RSD Q-P	14	25	55	31.3
	RSD P-M	0	12	0	4
		2011	2017	2018	Mean
Yellow perch	N	45	41	12	32.7
	CPUE (#/net-night)	22.5	20.5	6	16.3
	WPUE	1865.5	1563.5	418.5	1282.5
	Mean Length (mm)	179	172	188.8	179.9
	Mean Weight (g)	83	77	69.9	76.6
	Avg Wr	100	101.8	81.7	94.5
	PSD	13	46	33	30.7
	RSD S-Q	84	68	67	73
	RSD Q-P	13	46	33	30.7
	RSD P-M	2	0	0	0.7

#### 4. History of Angler Use

- a. The most desired species, by anglers, include northern pike, yellow perch, bluegill, and walleye. These are the species that are most sought after during all seasons. Based on population assessments, natural reproduction has been occurring with bluegill, northern pike, and yellow perch. Populations of these fish have remained constant each year.

### **D. History of Management Actions**

#### 1. Eradications

- a. There has been no local expression in regards to undesirable species found in Gordon Lake.

#### 2. Stocking

- a. The N.D. Game and Fish and the U.S. Fish and Wildlife Service provide stocking information. Walleye, northern pike, and yellow perch stockings have occurred historically.

#### 3. Special Regulations

- a. More information needed.

### **E. Management Problems**

#### 1. Physical/Chemical

- a. Gordon Lake suffers from a high nutrient load similar to Belcourt Lake. Phosphorous and nitrogen are two common nutrients that are found naturally in sediment released by decomposing plant matter. In balanced levels, these nutrients can help aquatic ecosystems thrive. Chronic nutrient loading can lead to water quality issues that will eventually affect Gordon Lake. Excess nutrient loads can cause undesired algae blooms that can cause fish kills.

The Turtle Mountain Band of Chippewa have collect water quality measurements since 2001. They requested the assistance of Houston Engineering, Inc. to identify the impacts of high nutrient loading in the Belcourt Lake watershed. Sources of this phosphorous loading includes Surface water runoff, atmospheric deposition, septic system loading, and discharge from upstream lakes.

The information collected will be useful in developing water quality goals, establish nutrient loading capacities, and provide a basis to improve management of the Belcourt Lake watershed.

#### 2. Development

- a. Facilities - Talk with the Turtle Mountain Department of Natural Resources and N.D. Game and Fish about piers, boat ramps, docks, lights, fish cleaning stations etc.

- b. Enhancement - None

3. Fishery
  - a. Walleye populations appear to remain constant over the last two years with a stable population.
  - b. Yellow perch continue to be small despite lowered abundance in 2018. It is unlikely that Gordon Lake will produce quality-sized perch.

**F. Management Goals and Objectives**

1. Goal
  - a. To maintain Gordon Lake as a rustic, secluded multi-purpose, recreational lake that provides the local community with a quality outdoor experience.
2. Objectives
  - a. To meet the management goal by maintaining a diverse quality sport fishery for walleye, yellow perch, northern pike, and bluegill.

**Table 6:** Accepted stock density index ranges for balanced fish populations. Target values by sampling effort and species should equal or exceed ranges.

<u>Species</u>	<u>Capture Rate</u>	<u>Wr</u>	<u>PSD</u>
walleye	10 fish/net-night	90	30-60
northern pike	5 fish/net-night	90	30-60
bluegill	10 fish/net-night	90	20-60
yellow perch	10 fish/net-night	90	30-60

- b. Improve habitat for desired species.
- c. Upgrade the capacity of the Turtle Mountain Department of Natural Resources to allow for improved monitoring and maintenance actions.
- d. Develop basic facilities and amenities to increase use of Gordon Lake during summer months.

**G. Proposed Management Actions**

1. Physical/Chemical
  - a. Reduce the current nutrient load in Gordon Lake. Vegetative buffer zones can be effective at capturing excess nutrients on a waterbody. These buffers can extend 3-5 feet around the shoreline and around drainage areas.
  - b. Another option would be to introduce an aeration system that increases dissolved oxygen. This would increase the activity of aerobic bacteria that would deter the growth of unwanted algae blooms.
  - c. Bank stabilization will need implementing to prevent further erosion of the shoreline.

2. Development
  - a. Discuss development opportunities with the Department of Natural Resources
3. Fishery
  - a. Stocking of walleye (odd years) will occur on an alternate year basis. Stocking rates will be dependent on the current population trends. There are no new introductions planned.
4. Sociological
  - a. Regulations – Talk to the department about current regulations on fish limits.
  - b. Information/Education – Information kiosks and signs posted at each boat ramp will inform the public on current regulations and management problems.
  - c. Interagency Communication – Coordinate with the Turtle Mountain Department of Natural Resources on sampling dates and data collected.

#### **H. Evaluation of Management Actions**

1. Evaluation Design
  - a. Summer population surveys will need to occur annually. These surveys will provide important information on population dynamics, size structure, relative abundance, condition, and reproductive success. The data collected will influence management decisions.
  - b. Water quality measurements are crucial and taken periodically during late summer and mid-winter.

#### **I. Other Management Options Considered**

1. Ideas?

#### **J. Projected Time Frame**

January-February	Conduct winter water quality sampling
June	Conduct summer population sampling
July-August	Conduct summer water quality sampling

#### **K. Literature Cited**

Carlander, K., Whitney, R., Speaker, E., and Madden, K. Evaluation of Walleye Fry Stocking in Clear Lake, Iowa, by Alternate-Year Planting. Transactions of the American Fisheries Society, Vol. 89, 3, pp 249-254 (1960).

Murphy, B. and Willis, D. *Fisheries Techniques Second Edition*. (1996)

Nielsen, L. and Johnson, D. *Fisheries Techniques*. (1989)

Osborne, L. and Kovacic, D. Riparian vegetated buffer strips in water-quality restoration and stream management. *Freshwater Biology*, 29, pp 243-258 (1993).



## VI. Wheaton Lake

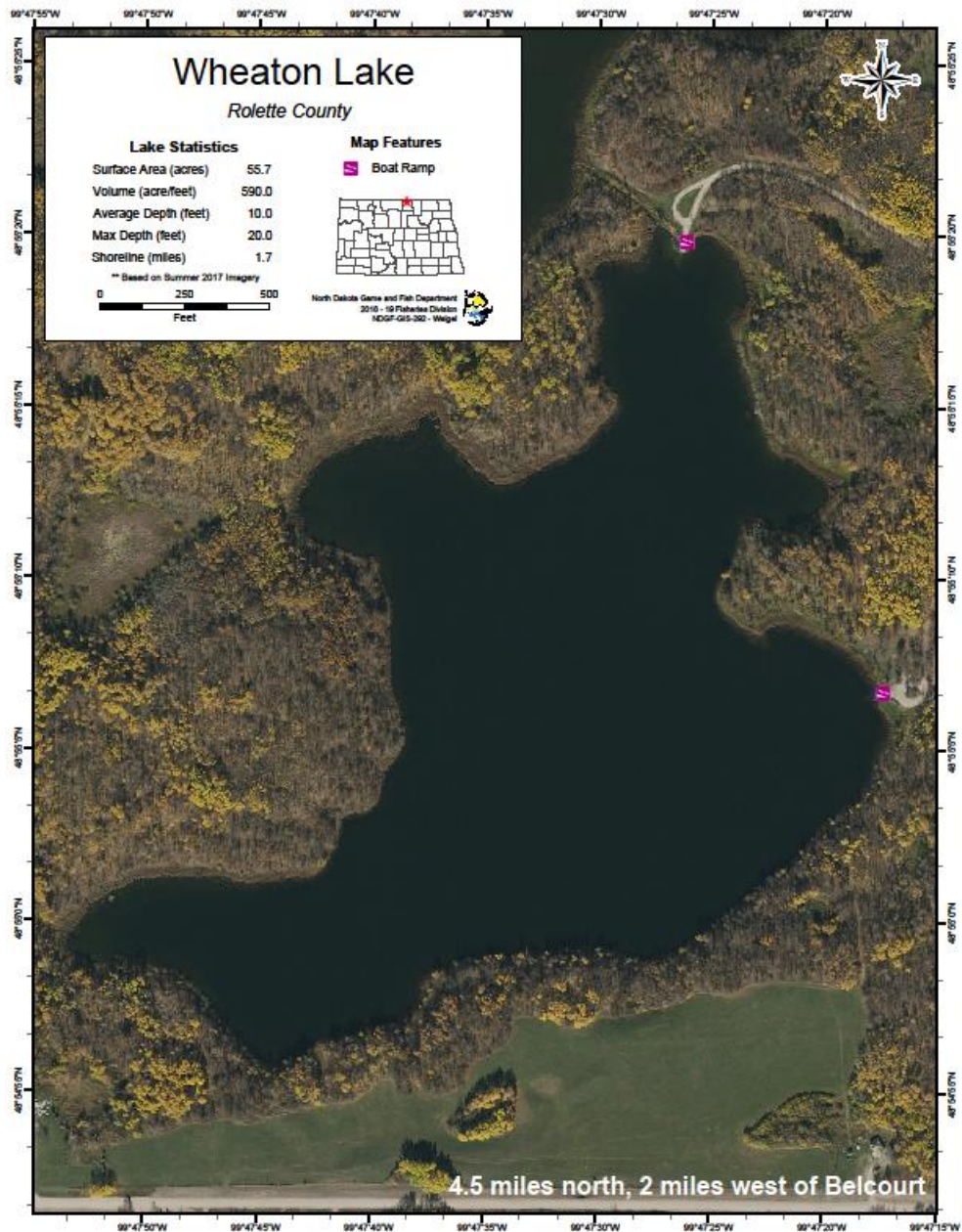

**Figure 3:** Wheaton Lake located 4.5 miles north and 2 miles west of Belcourt, ND. Picture taken from the ND Game and Fish website.

### A. Inventory

1. **Legal Description:** Township 163 N, Range 71 W, Sections 24 and 25.
2. **Location to nearest town:** 4.5 miles north, 2 miles west of Belcourt
3. **Ownership:** Considered federal waters by virtue of its location within trust lands of the Turtle Mountain Chippewa Reservation. Management of the lake lies primarily with the Turtle Mountain Band of Chippewa with trust oversight by the Bureau of Indian Affairs (USDOI).
4. **Type:** Naturally occurring glacial lake

5. **Size:** 59 surface acres
6. **Elevation:** Average elevation is 2109 feet amsl
7. **Maximum Depth:** 20-25 feet **Average Depth:** 10 feet
8. **Volume:** 590 acre-feet
9. **Shoreline miles:** 0.56 miles
10. **Priority Score:** Tier 3
11. **Lake Assessment:** None as of 2018
12. **Watershed Size:** Not determined
13. **Location of normal outlet:** The natural outlet is at the southwest corner of the lake flowing west.
14. **Littoral area:** 0-15 feet from shoreline

**B. Development**

1. Wheaton Lake has two boat ramps for recreational use. There are single poured concrete slab ramps that are accessible at the eastern and northern recreational beach areas. The Bureau of Indian Affairs places a dock adjacent to the boat ramp annually. Currently there are no piers, kiosks, toilet facilities, lighting, or fish cleaning facilities at Wheat Lake.

**C. Fishery**

1. General Description

- a. Wheaton Lake is a naturally occurring glacial lake formed by a dead-ice moraine. As glacial ice stopped advancing in the Turtle Mountains, large amounts of sediment accumulated on top of the ice. This insulation of sediment prevented the underlying ice from melting for several thousand years. This slow melting resulted in irregularities at the surface, causing the sediment on top of the ice to slump into lower areas. When this sediment slumped, the ice beneath the sediment began to melt more rapidly and transformed the area into a hole or a depression. These depressions created what are now the many lakes found in the Turtle Mountain area and the surrounding landscape.

2. Species List

**Table 7:** Fish species found in Wheaton Lake.

<b>Common</b>
northern pike - NR
yellow perch – NR
bluegill - NR
S- denotes stocked
NR – denotes natural reproduction

3. Population Status and Trend

a. **Northern Pike** – Northern pike introductions began in 1967 with zero fish stocked since 2012. Currently, natural reproduction maintains northern pike populations. Based on sampling from 2017 and 2018, northern pike catch rates have varied from six to 14 fish per net/night. Based on proportional stock densities, there are more northern pike in the quality to preferred range (64%) in 2017 (Table 6) than the quality to preferred range (54%) in 2018. Northern pike appear to have had a good spawn in 2017 with there being more standard to quality range (43%) fish captured in 2018 than standard to quality range (0%) fish captured in 2017.

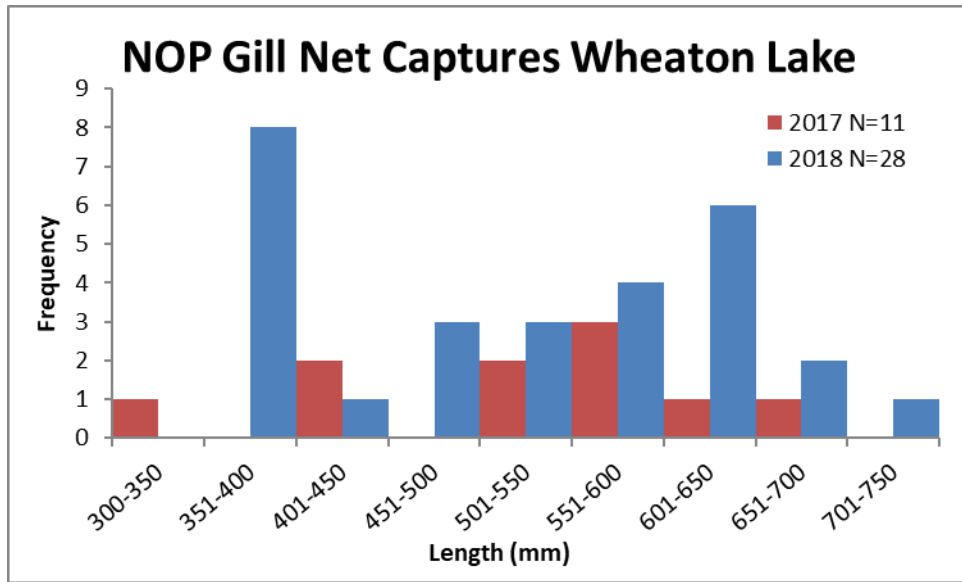

**Figure 6:** Length frequency histogram of northern pike found in Wheaton Lake from 2017 to 2018.

- b. **Bluegill** – Bluegill stocking never occurred in Wheaton Lake. Gill nets are inefficient at capturing bluegill with all bluegill captures occurring in trap nets. Trap net catches are composed primarily of small bluegill, which offer a forage for northern pike. Natural reproduction is occurring with bluegill.
- c. **Yellow perch** – Yellow perch introductions began in 1997 with one other stocking event occurring in 1998. Fish stock rates ranged from 85 to 135 fingerlings per acre. Currently, natural reproduction sustains yellow perch populations. Yellow perch catch rates have varied from 34 to 35 fish/net-night in 2017 and 2018. Based on proportional stock densities, a high percentage of yellow perch are in the stock to quality (62%) range on average (Table 6). Growth rates of yellow perch appear to slow down between 130 and 200 millimeters. Yellow perch populations do not meet the accepted proportional stock index ranges. Management of yellow perch is for a forage fish with few preferred fish in the population.

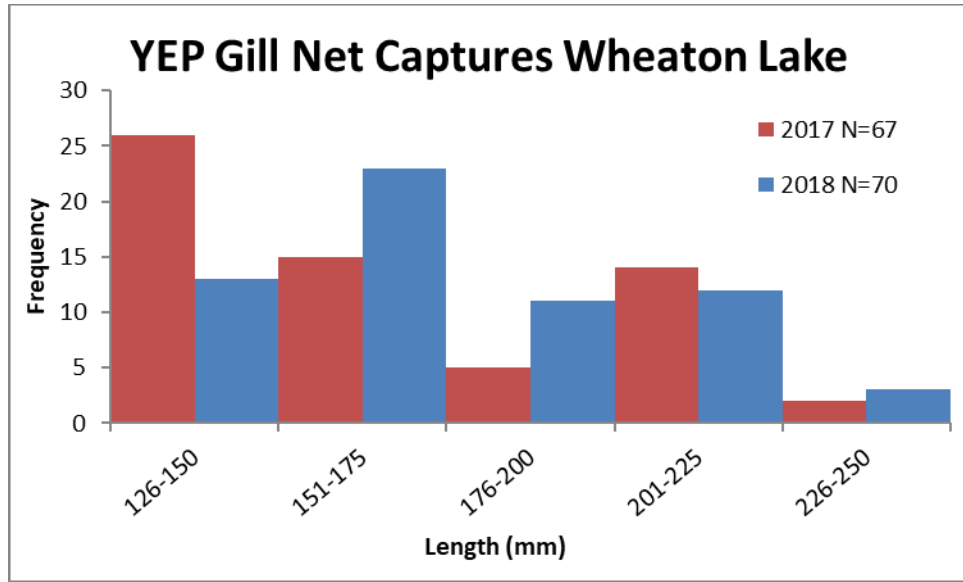

**Figure 7:** Length frequency history for yellow perch captures in Wheaton Lake from 2017 to 2018.

**Table 8:** Population trend – 6’ x 125’ x ¾” – 2” gill nets in Wheaton Lake from 2017 to 2018.

Target Species		2017	2018	Mean
Northern pike	N	11	28	19.5
	CPUE (#/net-night)	5.5	14	9.75
	WPUE	3967	12959	8463
	Mean Length (mm)	533	528.2	530.6
	Mean Weight (g)	991.8	996.9	994.35
	Avg Wr	100	96.7	98.35
	PSD	64	54	59
	RSD S-Q	0	43	21.5
	RSD Q-P	18	54	36
	RSD P-M	64	3	33.5
			2017	2018
Yellow perch	N	67	70	68.5
	CPUE (#/net-night)	33.5	35	34.25
	WPUE	2265.5	2349.5	2307.5
	Mean Length (mm)	171.9	176.6	174.25
	Mean Weight (g)	71.9	77	74.45
	Avg Wr	99.3	98.7	99
	PSD	30	26	28
	RSD S-Q	63	61	62
	RSD Q-P	30	26	28
	RSD P-M	1	0	1

#### 4. History of Angler Use

- a. The most desired species, by anglers, include northern pike, yellow perch, and bluegill. These are the species that are most sought after during all seasons. Based on population assessments, natural reproduction has been occurring with each species. Populations of these fish have remained constant each year.

#### **D. History of Management Actions**

##### 1. Eradications

- a. There has been no local expression in regards to undesirable species found in Wheaton Lake.

##### 2. Stocking

- a. The N.D. Game and Fish and the U.S. Fish and Wildlife Service provide stocking information. Walleye, northern pike, and yellow perch stockings have occurred historically.

##### 3. Special Regulations

- a. More information needed

#### **E. Management Problems**

##### 1. Physical/Chemical

- a. Wheaton Lake is in the same watershed as Gordon and Belcourt Lake. High nutrient loading could be a problem in the future.

##### 2. Development

- a. Facilities – Talk with the Turtle Mountain Department of Natural Resources and the N.D. Game and Fish about piers, boat ramps, docks, lights, fishing cleaning stations, etc.

- b. Enhancement – None

##### 3. Fishery

- a. Northern pike captures have increased in 2018 with smaller fish captured. Natural reproduction is occurring.
- b. Yellow perch numbers are high with their size remaining small. It is unlikely that Wheaton Lake will produce quality-size perch.

#### **F. Management Goals and Objectives**

##### 1. Goal

- a. To maintain Wheaton Lake as a rustic, secluded, multi-purpose, recreational lake that provides the local community with a quality outdoor experience.

##### 2. Objectives

- a. To meet management goals by maintaining a diverse quality sport fishery for northern pike, yellow perch, and bluegill.

**Table 9:** Accepted stock density index ranges for balanced fish populations. Target values by sampling effort and species should equal or exceed ranges.

<u>Species</u>	<u>Capture Rate</u>	<u>Wr</u>	<u>PSD</u>
northern pike	5 fish/net-night	90	30-60
bluegill	10 fish/net-night	90	20-60
yellow perch	10 fish/net-night	90	30-60

- b. Improve habitat for desired species
- c. Upgrade the capacity of the Turtle Mountain Department of Natural Resources to allow for improved monitoring and maintenance actions.
- d. Develop basic facilities and amenities to increase use of Wheaton Lake during summer months.

**G. Proposed Management Actions**

1. Physical/Chemical

- a. The Department will seek to maintain water levels at Wheaton Lake to maximize fish habitat and populations. Wheaton Lake will need to undergo similar management practices to Belcourt and Gordon Lake to prevent high nutrient loads and unwanted algae blooms.
- b. Reduce the current nutrient load in Wheaton Lake. Vegetative buffer zones can be effective at capturing excess nutrients on a waterbody. These buffers can extend 3-5 feet around the shoreline and around drainage areas.

2. Development

- a. Discuss development opportunities with the Department of Natural Resources

3. Fishery

- a. Stocking will not occur at Wheaton Lake in the near future. Northern pike and yellow perch populations are sustainable. There are no plans for introducing new species.

4. Sociological

- a. Regulations – Talk to the department about current regulations on fish limits.
- b. Information/Education – Information kiosks and signs posted at each boat ramp will inform the public on current regulations and management problems.
- c. Interagency Communication – Coordinate with the Turtle Mountain Department of Natural Resources on sampling dates and data collected.

## **H. Evaluation of Management Actions**

### **1. Evaluation Design**

- a. Summer population surveys will need to occur annually. These surveys will provide important information on population dynamics, size structure, relative abundance, condition, and reproductive success. The data collected will influence management decisions.
- b. Water quality measurement are crucial and taken periodically during late summer and mid-winter.

## **I. Other Management Options Considered**

### **1. Ideas?**

## **J. Projected Time Frame**

January- February	Conduct winter water quality sampling
June	Conduct summer population sampling
July-August	Conduct summer water quality sampling

## **K. Literature Cited**

- Bluemle, J. 2002. Buried Glaciers and Dead-ice Moraine. North Dakota Geological Survey.
- Murphy, B. and Willis, D. *Fisheries Techniques Second Edition*. (1996)
- Nielsen, L. and Johnson, D. *Fisheries Techniques*. (1989)
- Osborne, L. and Kovacic, D. Riparian vegetated buffer strips in water-quality restoration and stream management. *Freshwater Biology*, 29, pp 243-258 (1993).

## VII. Jarvis Lake

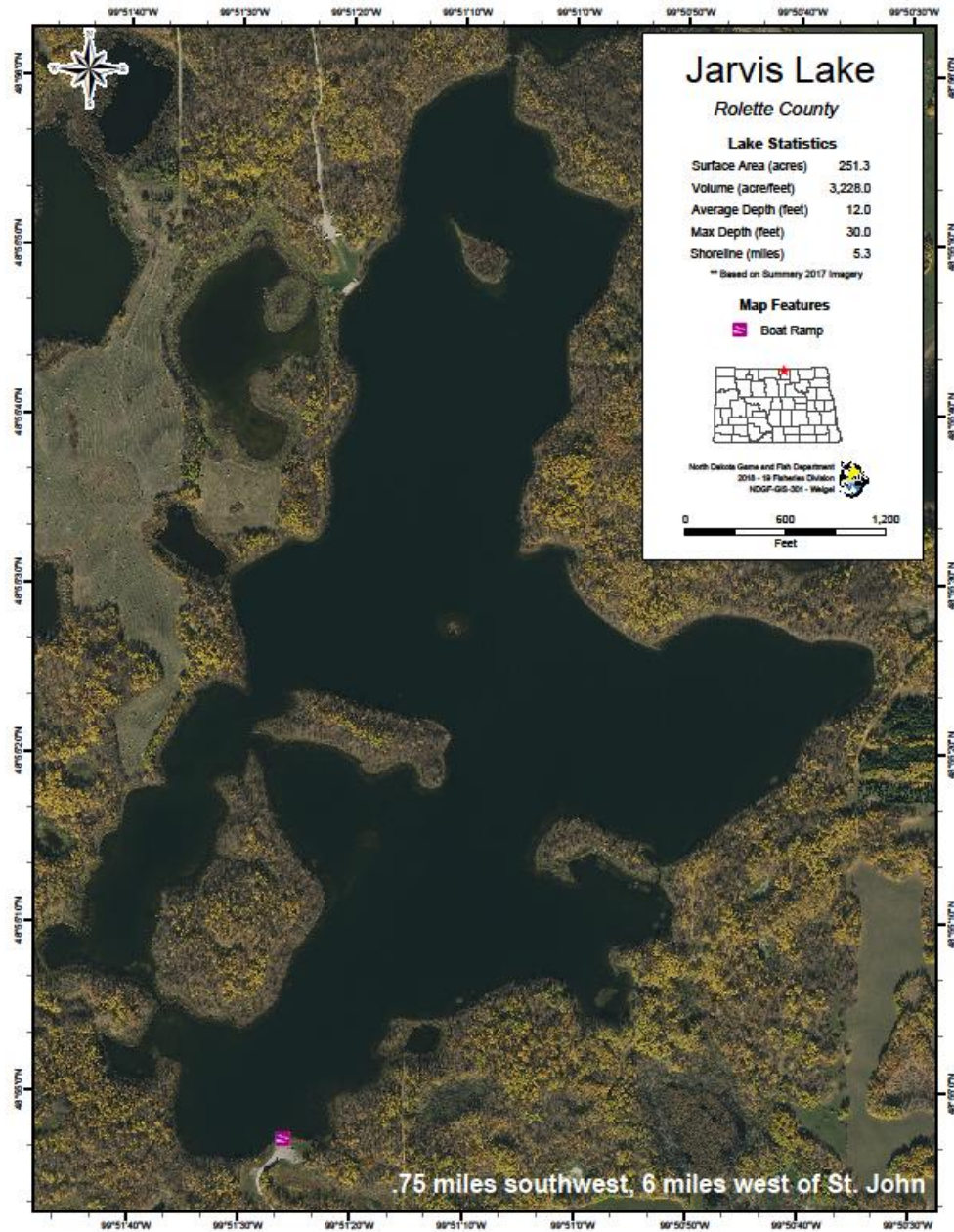

**Figure 4:** Jarvis Lake located  $\frac{3}{4}$  mile southwest and 6 miles west of St. John. Picture taken from the ND Game and Fish website.

### A. Inventory

1. **Legal Description:** Township 163 N, Range 71 W, Sections 21, 22, 27, and 28.
2. **Location to nearest town:** Approximately .75 miles southwest, and 6 miles west of St. John, ND.



3. **Ownership:** Considered federal waters by virtue of its location within the exterior boundaries of the Turtle Mountain Band of Chippewa Reservation. Management of the lake lies primarily with the Turtle Mountain Band of Chippewa with trust oversight by the Bureau of Indian Affairs (USDOJ).
4. **Type:** Naturally occurring glacial lake
5. **Size:** 251.3 Surface Acres
6. **Elevation:** Average elevation is 2135 feet amsl
7. **Maximum Depth:** 30 feet **Average Depth:** 12 feet
8. **Volume:** 3,228.0 acre/feet
9. **Shoreline miles:** 5.3 miles
10. **Priority Score:** Tier 3
11. **Lake Assessment:** None as of 2018
12. **Watershed Size:** Not determined
13. **Location of normal outlet:** The natural outlet is at the southwest corner of the lake flowing west.
14. **Littoral area:** 0-15 feet from shoreline

**B. Development**

1. Jarvis Lake has one primitive boat ramp for recreational use in the SW corner. The Bureau of Indian Affairs places a dock adjacent to the boat ramp annually. Currently there are not any piers, kiosks, toilet facilities, lighting, or fish cleaning facilities at Jarvis Lake.

**C. Fishery**

1. General Description
  - a. Jarvis Lake is a naturally occurring glacial lake formed by a dead-ice moraine. As glacial ice stopped advancing in the Turtle Mountains, large amounts of sediment accumulated on top of the ice. This insulation of sediment prevented the underlying ice from melting for several thousand years. This slow melting resulted in irregularities at the surface, causing the sediment on top of the ice to slump into lower areas. When this sediment slumped, the ice beneath the sediment began to melt more rapidly and transformed the area into a hole or a depression. These depressions created what are now the many lakes found in the Turtle Mountain area and the surrounding landscape.
2. Species List

**Table 10:** Fish Species found in Jarvis Lake.

Common	Uncommon
walleye - S	Fathead minnow - NR
northern pike - NR	
yellow perch - NR	
bluegill - NR	
S- denotes stocked	
NR - denotes natural reproduction	

3. Population Status and Trend

- a. **Walleye** – Walleye introductions began in 1910 with intermittent stocking since then. Since 2003, walleye stocking occurred each year (except 2011, 2012, and 2013) at rates ranging from 40 to 60 fingerlings per acre. There does not appear to be natural reproduction in Jarvis Lake.

Relative weights of walleye have remained steady ( $Wr's = 89.4$  to  $89.8$ ) in the past two years. Walleye catch rates have varied from seven to eight fish/net-night in the past two years of sampling. Based on proportional stock densities for 2018, walleye adult populations are comprised mostly of larger quality fish (46%) and preferred to memorable fish (31%) in 2018 (Table 8). The population appears to be healthy with many year classes present.

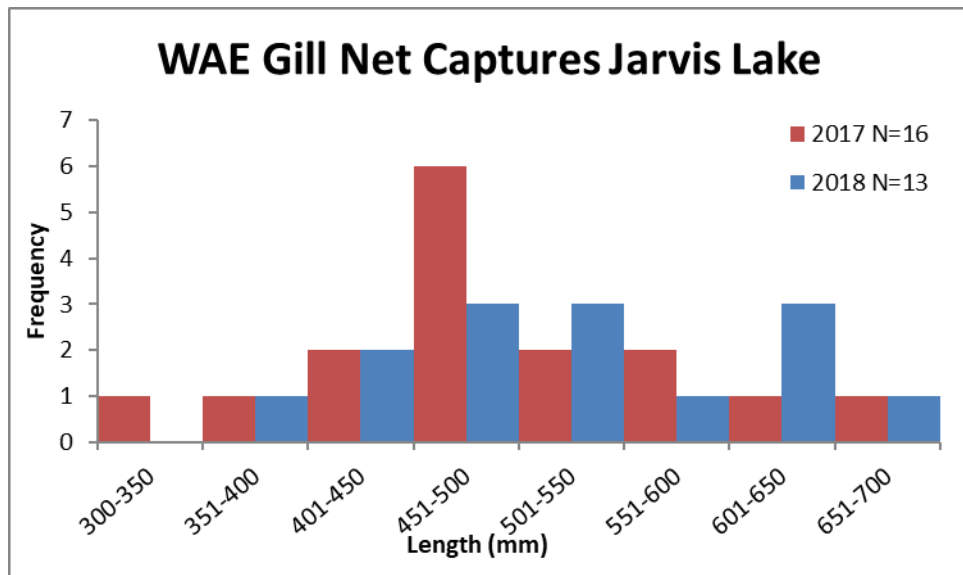

**Figure 7:** Length frequency histogram of walleye captured in Jarvis Lake from 2017-2018.

- b. **Northern Pike** – Northern pike introduction began in 1966 with intermittent stocking since then. Currently northern pike populations are reproducing naturally. Northern pike catch rates have varied from three to 12 fish/net-night in the past two years. Based on proportional stock densities, there are more northern pike in the stock to quality range (35%) in 2018 (Table 8) than in 2017 (0%). Northern pike seem to have had a good spawn in 2017 with there being less quality to preferred (26%) fish captured in 2018.

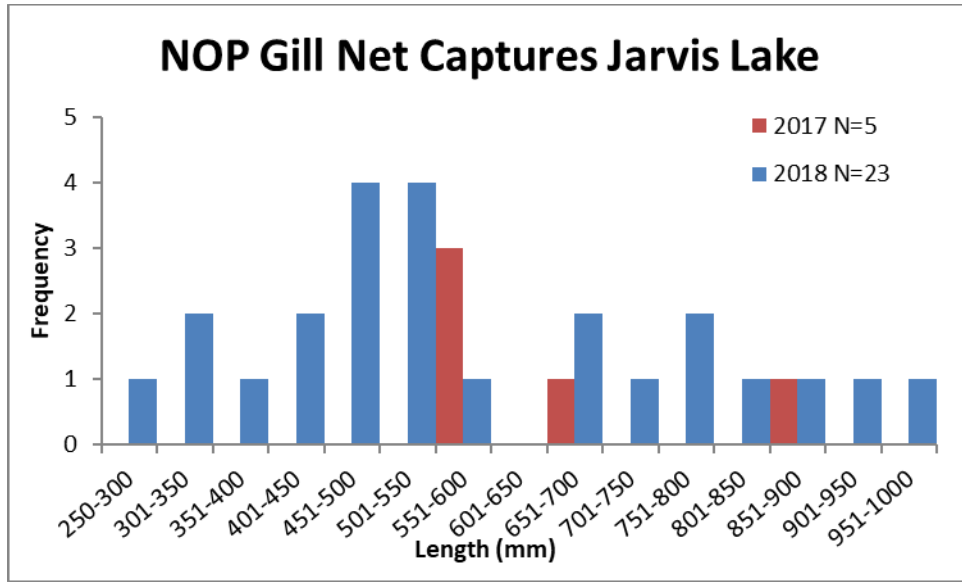

**Figure 8:** Length frequency histogram of northern pike captures in Jarvis Lake from 2017 to 2018.

- c. **Bluegill** – Bluegill introductions began in 1931 with intermittent stocking since then. Since 2003, bluegill stock rates ranged from 30 to 154 fingerlings per acre. Gill nets are inefficient at capturing bluegill with most captures coming from trap nets. Trap net catches are composed primarily of small bluegill, which offer forage for northern pike and walleye.

Bluegill catch rates varied from four to seven fish/net-night in the past two years. Based on proportional stock densities, all sampled fish were in the stock to quality range in 2017. In 2018, 62% sampled (Table 8) were in that range. There were also a large percentage of quality to preferred (38%) fish captured in 2018. Natural reproduction is occurring with bluegill.

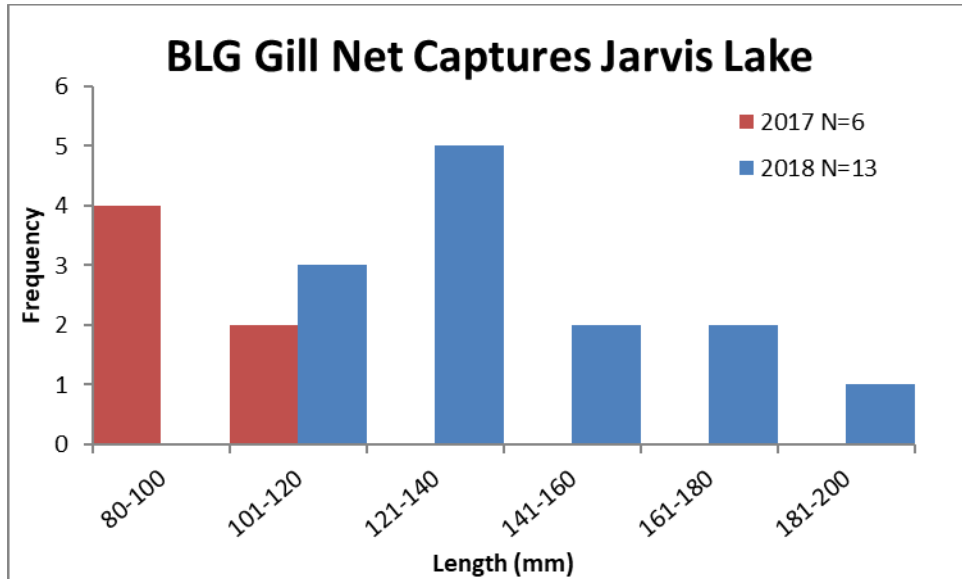

**Figure 9:** Length frequency histogram showing bluegill captures in Jarvis Lake from 2017 to 2018.

- d. **Yellow Perch** – Yellow perch introductions began in 1931 with intermittent stocking since then. Currently, natural reproduction sustains yellow perch populations. Yellow perch catch rates have varied from 45 to 71 fish per net/night in the past two years. Based on proportional stock densities, there are more stock to quality (61%) perch in Jarvis Lake than quality to preferred (26%) perch in 2018 (Table 8). Growth rates of yellow perch appear to slow between 200 to 250 mm. Management of yellow perch is for a forage fish with few preferred fish in the population.

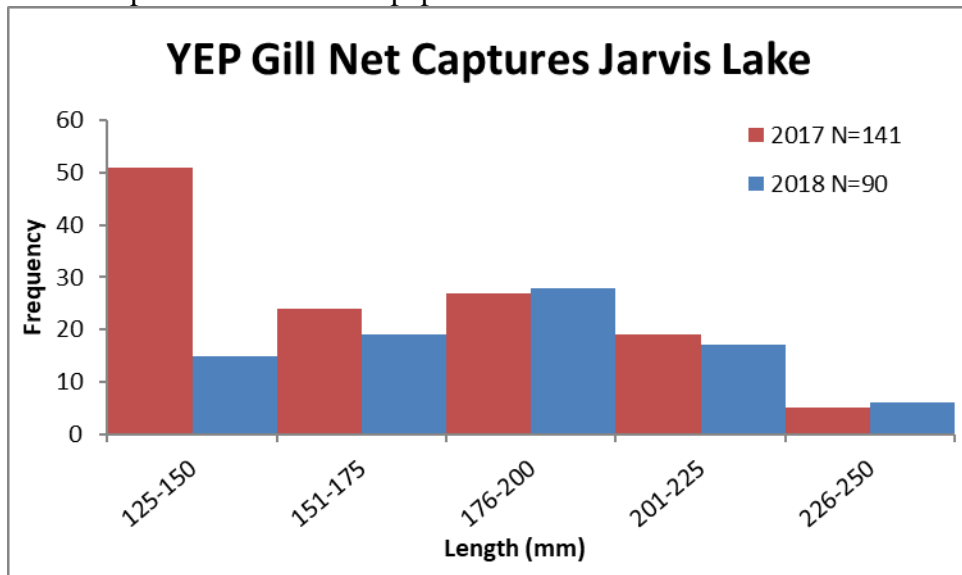

**Figure 10:** Length frequency histogram showing yellow perch captures in Jarvis Lake from 2017 to 2018.

**Table 11:** Population trend – 6' x 125' x ¾" – 2" gill nets in Jarvis Lake from 2011 to 2018.

Target Species		2011	2017	2018	Mean
Walleye	N	22	16	13	17
	CPUE (#/net-night)	11	8	6.5	8.5
	WPUE	7565	8941.5	10277	8927.8
	Mean Length (mm)	399.1	485.6	527.7	470.8
	Mean Weight (g)	687.7	1277.4	1581.1	1182.1
	Avg Wr	89.2	89.8	89.4	89.5
	PSD	14	44	31	29.7
	RSD S-Q	59	19	0	26
	RSD Q-P	14	44	46	34.7
	RSD P-M	27	31	31	29.7
	RSD M-T	0	6	23	9.7
		2011	2017	2018	Mean
Northern pike	N	6	5	23	11.3
	CPUE (#/net-night)	3	2.5	11.5	5.7
	WPUE	3500.5	4252.5	17634.5	8462.5
	Mean Length (mm)	529.2	664	576.9	590.0
	Mean Weight (g)	1166.8	2126.3	1603.1	1632.1
	Avg Wr	100.7	102.4	98.5	100.5
	PSD	33	80	26	46.3
	RSD S-Q	50	0	35	28.3
	RSD Q-P	33	80	26	46.3
	RSD P-M	17	20	13	16.7
	RSD M-T	0	0	13	13
		2011	2017	2018	Mean
bluegill	N	0	7	13	6.7
	CPUE (#/net-night)	0	3.5	6.5	3.3
	WPUE	0	48.5	462.5	170.3
	Mean Length (mm)	0	102	141.9	81.3
	Mean Weight (g)	0	33	71.2	34.7
	Avg Wr	0	119.6	108.9	76.2
	PSD	0	0	38	12.7
	RSD S-Q	0	86	62	46.3
	RSD Q-P	0	0	38	12.7
	RSD P-M	0	0	0	0

		2011	2017	2018	Mean
Yellow perch	N	73	141	90	101.3
	CPUE (#/net-night)	36.5	70.5	45	50.7
	WPUE	5297	3556	3060	3971
	Mean Length (mm)	210.7	178.2	181.3	190.1
	Mean Weight (g)	146.4	91.2	86.2	107.9
	Avg W <sub>r</sub>	103.2	99.2	97.5	99.9
	PSD	44	23	26	31
	RSD S-Q	37	49	61	49
	RSD Q-P	44	23	26	31
	RSD P-M	19	1	0	6.7

4. History of Angler Use

- a. The most desired species, by anglers, include walleye, northern pike, yellow perch, and bluegill. These are the species that are most sought after during all seasons. Based on population assessments, natural reproduction appears to be limited with walleye. Populations of these fish have remained constant with annual stocking and management measures.

**D. History of Management Actions**

1. Eradications

- a. There have been no local expression in regards to undesirable species found in Jarvis Lake.

2. Stocking

- a. The N.D. Game and Fish and the U.S. Fish and Wildlife Service provide stocking information. Walleye, bluegill, northern pike, yellow perch, black crappie, and rainbow trout have historically been stocked in Jarvis Lake.

3. Special Regulations

- a. **More Information Needed**

**E. Management Problems**

1. Physical/Chemical

- a. Jarvis Lake was included in the study conducted by Houston Engineering. Though it is not in the same watershed as the Belcourt Lake watershed, land use management will be crucial for preventing future nutrient loading in Jarvis Lake.

2. Development

- a. Facilities – **Talk with the Turtle Mountain Department of Natural Resources and N.D. Game and Fish about piers, boat ramps, docks, lights, fish cleaning stations, etc.**

- b. Enhancement – None
- 3. Fishery
  - a. Walleye numbers have remained constant in 2017 and 2018, with larger fish in the system. Natural reproduction does not appear to be occurring in high numbers.
  - b. Yellow perch numbers are high with their size remaining small. It is unlikely that Jarvis Lake will produce quality-size perch.

**F. Management Goals and Objectives**

- 1. Goal
  - a. To maintain Jarvis Lake as a rustic, secluded, multi-purpose, recreational lake that provides the local community a quality outdoor experience.
- 2. Objectives
  - a. To meet management goals by maintaining a diverse quality sport fishery for walleye, yellow perch, northern pike, and bluegill.

**Table 12:** Accepted stock density index ranges for balanced fish populations. Target values by sampling effort and species should equal or exceed ranges.

<u>Species</u>	<u>Capture Rate</u>	<u>Wr</u>	<u>PSD</u>
walleye	10 fish/net-night	90	30-60
northern pike	5 fish/net-night	90	30-60
bluegill	10 fish/net-night	90	20-60
yellow perch	10 fish/net-night	90	30-60

- b. Improve habitat for desired species.
- c. Upgrade the capacity of the Turtle Mountain Department of Natural Resources to allow for improved monitoring and maintenance actions.
- d. Develop basic facilities and amenities to increase use of Jarvis Lake during summer months.

**G. Proposed Management Actions**

- 1. Physical/Chemical
  - a. The Department will seek to maintain water levels at Jarvis Lake to maximize fish habitat and populations.
- 2. Development
  - a. Discuss development opportunities with the Department of Natural Resources
- 3. Fishery
  - a. Stocking of walleye (even years) will occur on an alternate year basis. Stocking rates will be dependent on the current population trends. There are no plans for introducing new species.

4. Sociological
  - a. Regulations – Talk to the department about current regulations on fish limits.
  - b. Information/Education – Information kiosks and signs posted at each boat ramp will inform the public on current regulations and management problems.
  - c. Interagency Communication – Coordinate with the Turtle Mountain Department of Natural Resources on sampling dates and data collected.

**H. Evaluation of Management Actions**

1. Evaluation Design
  - a. Summer population surveys will need to occur annually. These surveys will provide important information on population dynamics, size structure, relative abundance, condition, and reproductive success. The data collected will influence management decisions.
  - b. Water quality measurements are crucial and taken periodically during late summer and mid-winter.

**I. Other Management Options Considered**

**1. Ideas?**

**J. Projected Time Frame**

January-February	Conduct winter water quality sampling
June	Conduct summer population sampling
July-August	Conduct summer water quality sampling

**K. Literature Cited**

Bluemle, J. 2002. Buried Glaciers and Dead-ice Moraine. North Dakota Geological Survey.

Murphy, B. and Willis, D. *Fisheries Techniques Second Edition*. (1996)

Nielsen, L. and Johnson, D. *Fisheries Techniques*. (1989)



## VIII. Martin Lake



### A. Inventory

1. **Legal Description:** Township 162N, Range 70W, Sections 14 and 15
2. **Location to nearest town:** 1.2 miles east, 1 mile north, and 0.8 miles east of Belcourt
3. **Ownership:** Martin Lake is considered federal waters by virtue of its location within trust lands of the Turtle Mountain Chippewa Reservation. Management of the lake lies primarily with the Turtle Mountain band of Chippewa with trust oversight by the Bureau of Indian Affairs (USDOI).
4. **Type:** Naturally occurring glacial lake
5. **Size:** 171.9 acres
6. **Elevation:** 1989 feet amsl
7. **Maximum Depth:** 19 feet found in 2018 sampling **Average Depth:** Unknown
8. **Volume:** Unknown
9. **Shoreline miles:** 6.2 miles
10. **Priority Score:** Unknown
11. **Lake Assessment:** None as of 2018

- 12. **Watershed Size:** Not determined
- 13. **Location of normal outlet:** Unknown
- 14. **Littoral area:** Unknown

**B. Development**

- 1. Martin Lake does not currently have a boat ramp. The main access is on the Northeast part of the lake along BIA Rd. 6. Currently there are no piers, docks, toilet facilities, or fish cleaning facilities at Martin Lake.

**C. Fishery**

1. General Description

- a. Martin Lake is a naturally occurring glacial lake formed by a dead-ice moraine. As glacial ice stopped advancing in the Turtle Mountains, large amounts of sediment accumulated on top of the ice. This insulation of sediment prevented the underlying ice from melting for several thousand years. This slow melting resulted in irregularities at the surface, causing the sediment on top of the ice to slump into lower areas. When this sediment slumped, the ice beneath the sediment began to melt more rapidly and transformed the area into a hole or a depression. These depressions created what are now the many lakes found in the Turtle Mountain area and the surrounding landscape.

2. Species List

**Table 13:** Fish species found in Martin Lake.

<b>Common</b>
yellow perch – NR
fathead minnow - NR
NR – Denotes Natural Reproduction

3. Population Status and Trend

- a. **Yellow perch** – With sampling of Martin Lake only occurring in 2018, there is not enough data collected to determine a population trend. Yellow perch have never been stocked by the U.S. Fish and Wildlife Service, but there is natural reproduction occurring. Based on adult population sampling in 2018, there appears to be too many yellow perch (Table 10) in the lake. With the population size being too large, yellow perch are unable to grow to a quality size.

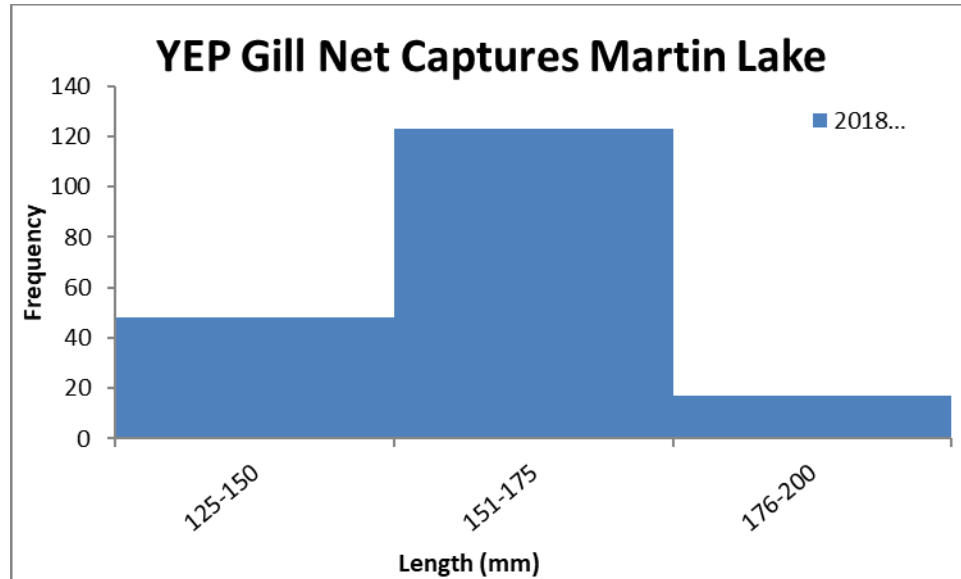

**Figure 11:** Length frequency histogram of yellow perch captures in Martin Lake in 2018.

**Table 14:** Population trend – 6’ x 125’ x ¾” – 2” gill nets in Martin Lake.

Target Species		2018
Yellow perch	N	219
	CPUE (#/net-night)	109.5
	WPUE	2222
	Mean Length (mm)	160.6
	Mean Weight (g)	53.5
	Avg Wr	94.1
	PSD	0
	RSD S-Q	100
	RSD Q-P	0
	RSD P-M	0

4. History of Angler Use

- a. The most desired species, by anglers, include northern pike, yellow perch, bluegill, and walleye. These are the species that are most sought after during all seasons. Anglers are interested in having more walleye lakes on the Turtle Mountain Reservation. Martin Lake could develop into a good walleye fishery based on current forage species present.

**D. History of Management Actions**

1. Eradications

- a. There has been no local expression in regards to undesirable species found in Martin Lake.
- b.

2. Stocking
  - a. The N.D. Game and Fish and the U.S. Fish and Wildlife Service provide stocking information. There have not been any fish stocked in Martin Lake.
3. Special Regulations
  - a. **More information needed**

**E. Management Problems**

1. Physical/Chemical
  - a. With too many yellow perch in the system, a predator introduction will keep yellow perch levels sustainable.
2. Development
  - a. Facilities – There currently is not a boat ramp or any facilities on Martin Lake. The development of a primitive boat ramp on the northeast part of the lake is in discussion. The development of a boat ramp, fishing piers, and a boat dock will be crucial for the public to gain access to Martin Lake.
  - b. Enhancement – None
3. Fishery
  - a. Populations will need monitoring each year to ensure they are sustainable.
4. Sociological
  - a. As a potential new walleye fishery, anglers will need to be patient for the fishery to grow. It could take a few years for future stockings to develop into quality size fish.

**F. Management Goals and Objectives**

1. Goal
  - a. To develop Martin Lake as a rustic, secluded, multi-purpose, recreational lake that provides the local community with a quality outdoor experience.
2. Objectives
  - a. To meet management goals by developing a diverse quality sport fishery for yellow perch and walleye.

**Table 15:** Accepted stock density index ranges for balanced fish populations. Target values by sampling effort and species should equal or exceed ranges.

<u>Species</u>	<u>Capture Rate</u>	<u>Wr</u>	<u>PSD</u>
walleye	10 fish/net-night	90	30-60
yellow perch	10 fish/net-night	90	30-60

- b. Improve habitat for desired species.

- c. Upgrade the capacity of the Turtle Mountain Department of Natural Resources to allow for improved monitoring and maintenance actions.
- d. Develop basic facilities and amenities to increase use of Martin Lake during summer months.

**G. Proposed Management Actions**

- 1. Physical/Chemical
  - a. The department will seek to maintain water levels at Martin Lake to maximize fish habitat and populations. Future population sampling and water quality measurements to ensure the lake is healthy enough to sustain fish populations.
- 2. Development
  - a. Discuss development opportunities with the Department of Natural Resources
- 3. Fishery
  - a. A recommendation of the stocking of walleye on an alternate year basis (odd years). Stocking rates will be dependent on the current population trends.
- 4. Sociological
  - a. Regulations – Talk to the department about current regulations on fish limits.
  - b. Information/Education – Information kiosks and signs posted at each boat ramp will inform the public on current regulations and management problems.
  - c. Interagency Communication – Coordinate with the Turtle Mountain Department of Natural Resources on sampling dates and data collected.

**H. Evaluation of Management Actions**

- 1. Evaluation Design
  - a. Summer population surveys will need to occur annually. These surveys will provide important information on population dynamics, size structure, relative abundance, condition, and reproduction success. The data collected will influence management decisions.

**I. Other Management Options Considered**

- 1. Ideas?

**J. Projected Time Frame**

January-February	Conduct winter water quality sampling
June	Conduct summer population sampling
July-August	Conduct summer water quality sampling

**K. Literature Cited**

Carlander, K., Whitney, R., Speaker, E., and Madden, K. Evaluation of Walleye Fry Stocking in Clear Lake, Iowa, by Alternate-Year Planting. Transactions of the American Fisheries Society, Vol. 89, 3, pp 249-254 (1960).

Murphy, B. and Willis, D. *Fisheries Techniques Second Edition*. (1996)

Nielsen, L. and Johnson, D. *Fisheries Techniques*. (1989)

## IX. Crow Lake



### A. Inventory

1. **Legal Description:** Township 163N, Range 71W, Section 15
2. **Location to nearest town:** ½ mile N, 6.5 miles W, ½ mile S of St. John
3. **Ownership:** Crow Lake is federal waters by virtue of its location within trust lands of the Turtle Mountain Chippewa Indian Reservation. Management of the lake lies primarily with the Turtle Mountain Band of Chippewa with trust oversight by the Bureau of Indian Affairs (USDOI).
4. **Type:** Naturally occurring glacial lake
5. **Size:** 58.5 acres
6. **Elevation:** 2123 feet amsl
7. **Maximum Depth:** 22 feet found in 2018 **Average Depth:** Unknown
8. **Volume:** Unknown
9. **Shoreline miles:** 2 miles
10. **Priority Score:** Unknown

11. **Lake Assessment:** None as of 2018
12. **Watershed Size:** Not determined
13. **Location of normal outlet:** Unknown
14. **Littoral area:** Unknown

**B. Development**

1. Crow Lake does not currently have a boat ramp. The main access is on the Southwest corner of the lake. Currently there are no piers, docks, toilet facilities, or fish cleaning facilities at Crow Lake.

**C. Fishery**

1. **General Description**

- a. Crow Lake is a naturally occurring glacial lake formed by a dead-ice moraine. As glacial ice stopped advancing in the Turtle Mountains, large amounts of sediment accumulated on top of the ice. This insulation of sediment prevented the underlying ice from melting for several thousand years. This slow melting resulted in irregularities at the surface, causing the sediment on top of the ice to slump into lower areas. When this sediment slumped, the ice beneath the sediment began to melt more rapidly and transformed the area into a hole or a depression. These depressions created what are now the many lakes found in the Turtle Mountain area and the surrounding landscape.

2. **Species List**

**Table 16:** Fish species found in Crow Lake.

<b>Common</b>
yellow perch – NR
fathead minnow – NR
brook stickleback - NR
NR – Denotes Natural Reproduction

3. **Population Status and Trend**

- a. **Yellow perch** – With sampling in Crow Lake only occurring in 2018, there is not enough data collected to determine a population trend. The U.S. Fish and Wildlife Service have never stocked yellow perch, but there is natural reproduction occurring (Table 12). Based on adult population sampling in 2018, it is difficult to make any management decisions at this time.



**Table 17:** Population trend – 6’ x 125’ x ¾”-2” gill nets in Crow Lake.

Target Species		2018
Yellow perch	N	6
	CPUE (#/net-night)	3
	WPUE	81.5
	Mean Length (mm)	143
	Mean Weight (g)	38.6
	Avg Wr	103.1
	PSD	0
	RSD S-Q	83
	RSD Q-P	0
	RSD P-M	0

4. History of Angler Use

- a. The most desired species, by anglers, include northern pike, yellow perch, bluegill, and walleye. These are the species that are most sought after during all seasons. Anglers are interested in having more walleye lakes on the Turtle Mountain Reservation. Crow Lake has the potential to develop as a good walleye and yellow perch fishery.

**D. History of Management Actions**

1. Eradications

- a. There has been no local expression in regards to undesirable species found in Crow Lake.

2. Stocking

- a. The N.D. Game and Fish and the U.S. Fish and Wildlife Service provide stocking information. There have not been any fish stocked in Crow Lake.

3. Special Regulations

- a. More information needed

**E. Management Problems**

1. Physical/Chemical

- a. There is not enough data collected from Crow Lake to make any management decisions.

2. Development

- a. Facilities – There currently is not a boat ramp or any facilities at Crow Lake. Development of Crow Lake will not occur until there is an established fishery.
- b. Enhancement – None

3. Fishery
  - a. With little information available from Crow Lake and very few fish captures in 2019, more information and data is necessary.

**F. Management Goals and Objectives**

1. Goal
  - a. To develop Crow Lake as a rustic, secluded, multi-purpose, recreational lake that provides the local community with a quality outdoor experience.
2. Objectives
  - a. To meet management goals by developing a diverse quality sport fishery for yellow perch and possibly walleye in the future.

**Table 18:** Accepted stock density index ranges for balanced fish populations. Target values by sampling effort and species should equal or exceed ranges.

<u>Species</u>	<u>Capture Rate</u>	<u>Wr</u>	<u>PSD</u>
yellow perch	10 fish/net-night	90	30-60

- b. Improve habitat for desired species.
- c. Upgrade the capacity of the Turtle Mountain Department of Natural Resources to allow for improved monitoring and maintenance actions.
- d. Develop basic facilities and amenities to increase use of Crow Lake during summer months.

**G. Proposed Management Actions**

1. Physical/Chemical
  - a. The department will seek to maintain water levels at Crow Lake to maximize fish habitat and populations. Future population sampling and water quality measurements to ensure the lake is healthy enough to sustain fish populations.
2. Development
  - a. There are currently no plans for development until a fishery is established.
3. Fishery
  - a. There are currently no plans to stock Crow Lake. Stocking will be dependent on the current population trends.
4. Sociological
  - a. Regulations – Talk to the department about current regulations on fish limits.
  - b. Information/Education – Information kiosks and signs posted at each boat ramp will inform the public on current regulations and management problems.

- c. Interagency Communication – Coordinate with the Turtle Mountain Department of Natural Resources on sampling dates and data collected.

**H. Evaluation of Management Actions**

1. Evaluation Design

- a. Summer population surveys will occur annually. These surveys will provide important information on population dynamics, size structure, relative abundance, condition, and reproductive success. The data collected will influence management decisions.

**I. Other Management Options Considered**

1. **Ideas?**

**J. Projected Time Frame**

January-February	Conduct winter water quality sampling
June	Conduct summer population sampling
July-August	Conduct summer water quality sampling

**K. Literature Cited**

Carlander, K., Whitney, R., Speaker, E., and Madden, K. Evaluation of Walleye Fry Stocking in Clear Lake, Iowa, by Alternate-Year Planting. Transactions of the American Fisheries Society, Vol. 89, 3, pp 249-254 (1960).

Murphy, B. and Willis, D. *Fisheries Techniques Second Edition*. (1996)

Nielsen, L. and Johnson, D. *Fisheries Techniques*. (1989)



# **TURTLE MOUNTAIN BAND OF CHIPPEWA INDIANS**

4180 Hwy 281  
P.O. BOX 900  
BELCOURT, ND 58316

(701) 477-2600  
Fax: (701) 477-0916  
[www.tmchippewa.com](http://www.tmchippewa.com)

September 7, 2023

ND Industrial Commission  
State Capital 14<sup>th</sup> Floor  
600 E. Boulevard Ave., Dept. 405  
Bismarck, ND 58505-0840

Commission Board:

## *Letter of Support & Commitment*

On behalf of the Turtle Mountain Band of Chippewa Tribal Government, I extend my support and commitment to our Natural Resources Department's application to the ND Industrial Commission for an Outdoor Heritage Fund grant. The proposed project to build access docks at our tribal lakes will be highly beneficial for our tribal members as well as visitors to the TM Chippewa Reservation. In addition to providing recreational opportunities, it will provide access to tribal waterways so that we can make continual improvement to fish & wildlife habitats.

Because of our growing population, it is essential that we invest time and resources to continually monitor and analyze the health of our tribal lakes and waterways. Additionally, we also want to assure there are ample recreational opportunities so that our tribal members live a healthy lifestyle that outdoor activities will provide. The Park has walking trails and other amenities that sway people away from sedentary lifestyles.

Planning is essential to development so I have committed time to be involved in the development of the Sky Chief Park and the Natural Resources department. I will continue to work with the TMBCI Tribal Council to leverage the financial resources necessary to move the tribe toward implementation of the many initiatives developed and sponsored at Sky Chief Park. As such, along with my support, I will assure that TMBCI Tribal Government will meet a 25% OHF match requirement through tribal financial resources. I also assure that the Sky Chief Park will continue to be publicly accessible to tribal members as well as visitors to the Turtle Mountain Chippewa Reservation.

Sincerely,

A handwritten signature in blue ink, appearing to read "Ron W. Trottier".

Ron Trottier, TMBCI District Two Representative/Treasurer

cc: TMBCI Tribal Government